

# LIFEPLATE<sup>®</sup> 2.0

User Guide

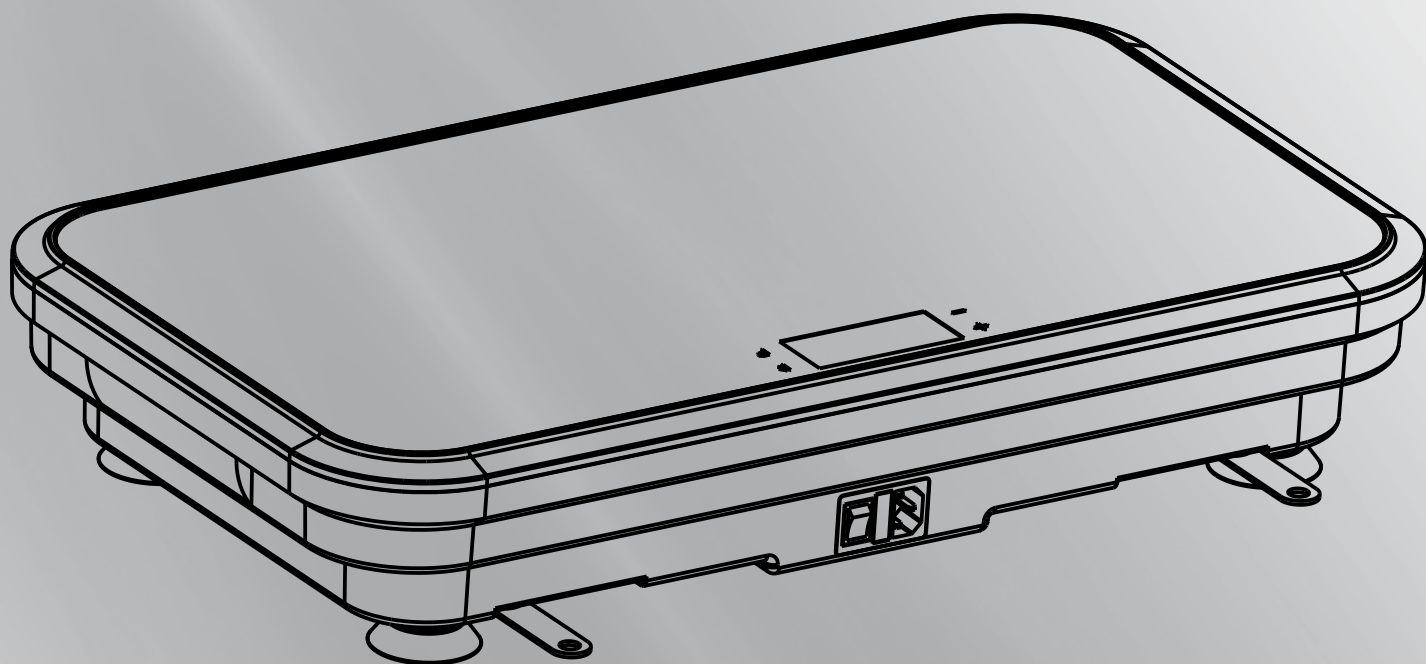

ENG

**LIFEPLATE<sup>®</sup>**  
vibration technology

## Index

Index	2
General Information and Warnings	2
Safety Instructions	3
Overview of the Device	4
Operation	5-7
Training	8-9
Mains Connection	10
Attaching the Training Belts	10
Recommended Accessories	10
Technical Information	11
Cleaning and Maintenance	11
Location & Storage	11
Technical Details	12
Error Messages	12
Disposal	12
Exploded Drawing & Parts List	13
Warranty	14
Damage Report / Repairs Contract	15

## General Information and Warnings

Training with a vibration plate is a very comprehensive training method, which in addition to influencing the muscles it also influences the rest of the body. For example, blood circulation is stimulated, and body metabolism is improved. For some years, professional and top athletes have used vibration equipment in training for its intensive and effective athletic effects, and for therapeutic purposes.

In fitness gyms vibration plates are now often found and they are becoming increasingly popular and enjoyed by more and more users. Due to the gentle but also highly effective training with vibration plates, many physiotherapy practices use these devices to build muscles up again after injuries or for rehabilitation purposes. With the appropriate professional advice from your therapist, you can now use a vibration plate at home for both therapeutic and sport training purposes.

Please keep in mind when planning your workouts that training with a vibration plate, while being very gentle on the body, is still very intense. Therefore, give your body enough time to rest between each individual training. In addition to the intensive and effective muscle training provided by a vibration plate, it also has other, very positive effects on the body.

For example, this type of training has a major impact on bone density. The metabolism is optimally stimulated by the vibrations, and this can have a positive effect on the fat loss.

If the following points apply to you, you should always clarify in advance with your doctor, if and how training with a vibration plate could be good for you:

- Pacemaker
- Tumors
- Epilepsy
- Acute wounds
- Freshly used spiral
- Acute inflammation
- Metal or plastic based implants
- Kidney, gallbladder and / or bladder stones
- Diabetes
- Disc degeneration
- Cardiovascular diseases
- Thrombosis
- Metastases
- Recent operations
- Pregnancy
- Acute fractures
- Acute infections, eg. flu-or similar
- Dental implants
- Muscle and joint diseases
- Deformation of bones and / or joints
- Heart and Cardiovascular Diseases

If you have any medical conditions, restrictions or complaints that are not mentioned here, please discuss with your consulting doctor or therapist if and how you should train on this device before you start training.

Please read and observe all sections of this Operating Manual. Thorough attention should always be paid to the safety instructions, the maintenance instructions and the training information.

It is very important to adhere strictly to the maintenance and safety instructions and maintenance instructions contained in this Manual.

This training device is only to be used for its intended purpose. If this equipment is used for any other purposes than intended, there is a possible risk of accident, damage to health or damage to the training device. The Distributor cannot be held responsible in these circumstances.

### Electrical Connection

- Always remove the electric plug from the socket before moving the training device.
- Remove the electric plug from the socket before commencing any cleaning, maintenance or other works.
- Do not connect the mains plug to a socket on a socket strip or on a cable drum.
- Always place the mains cable so it cannot be damaged or cause a tripping hazard.

### Training Environment

- Select a suitable space for your training device to provide an optimum amount of free space and highest level of safety. You should leave a free space of at least 150 cm behind, 150 cm to each side and a minimum of 100 cm in front of the training device.
- Make sure that the area is well ventilated and that an optimum amount of oxygen is available during training. Avoid draughts.
- Your training device is not suitable for outside use and so storage and training can only take place in a temperate, clean dry room.
- Do not operate or store your training device in wet areas such as in swimming pools, saunas etc.
- Make sure that your training device is kept on flat, hard, clean ground both in operation and at rest. Any uneven surfaces must be removed or made good.
- It is recommended that a floor covering (carpet, mat, etc.) should be placed under the device to protect damageable floors such as wood, laminates, floor tiles etc. Please ensure that this underlay cannot slip or slide.
- Do not put this training device on pale or white coloured carpets or rugs as the feet of the device may leave marks.
- Make sure that your training device and mains cable are kept out of contact with hot surfaces and are kept at a safe distance from any sources of heat e.g. central heating, hot stoves, furnaces, ovens or open fires.

### Personal Safety Instructions for Training

- The mains cable should be removed while the device is not in use to avoid any misuse or uncontrolled use by a third party, for example, by children
- You should have a health check carried out by your doctor before you start any training
- Stop training immediately if you feel physically unwell or are experiencing any breathing difficulties.
- Always start your training session at a low workload increasing it slowly but steadily throughout. Reduce the workload again towards the end of your training session.
- Suitable sports shoes and clothes should always be worn during training sessions. Make sure that loose clothes do not get caught up in the treadmill belt or rollers.
- Your training device is only to be used by one person at a time.
- Check each time before a training session to see if your device is in perfect condition. Never use your training device if it is faulty or defective.
- You are only permitted to carry out repairs to the device yourself after having contacted our Service Department and on receipt of explicit permission to do so. Only original spare parts may be used at any time.
- Your training device must be cleaned after each use. Remove all dirt including body sweat or any other liquids.
- Always make sure that liquids (drinks, body sweat, etc.) do not get onto the vibrating plate or into the cockpit as this can cause damage to the mechanical and electronic components.
- Your training device is not suitable for use by children. Children under 12 years are not permitted to use this device. Children over 12 years are permitted to use the device but only under the supervision of an adult.
- Third parties, especially children and animals, must be kept at a safety distance of at least 3m from the device during training.
- Check if there are any items underneath the training device before each training session and remove them without fail. Never use the training device when items are underneath it.
- Do not allow children to use your training device as a toy or climbing frame at any time.
- Ensure that no body parts of your own or of third parties ever get into contact with any of the moving mechanisms.

The construction of this training device is based on state-of-the-art technology and highest modern technical safety standards. This training device is to be used by adults only! Extreme misuse and/or unplanned training can cause damage to your health!

## Overall View of the Device

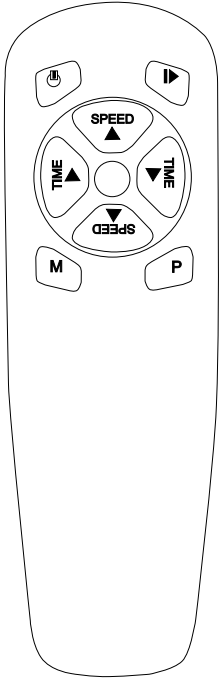

### Remote Control

- Power Key** Key to switch the vibration plate on and off
- Play/Pause Key** Key to start or end training
- TIME ▼** The standard time setting is 10:00 minutes. You can reduce the training time by pressing this key.
- TIME ▲** By pressing this key you can increase the training time by a maximum of 10:00
- SPEED ▼** By pressing this key the training level and vibration frequency of the plate can be increased from 1 to 60.
- SPEED ▲** By pressing this key the training level and vibration frequency of the plate can be decreased
- M Key** Quick selection key. By pressing this key, you can select level 20, 40 and 60 direct.
- P Key** Selection key for programs P1 to P5.

## Display and Display Keypad

The LCD display on the vibration plate informs you about the current training level and training time during training.

### +/- Keys

Before training: Specification of the training time  
During training: Adjustment of the training levels

### Play/Pause Key

Starts / Ends the training session

### P Key

Key to select the training programs P1 to P5

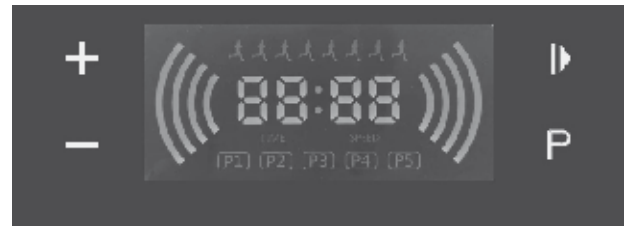

## Main Switch and Electrical Connection

### Main Switch

Switch to switch the vibration plate on and off.  
Position "I" – the device is switched on  
Position "0" – the device is switched off

### Electrical Connection

Connect the mains cable included in delivery.

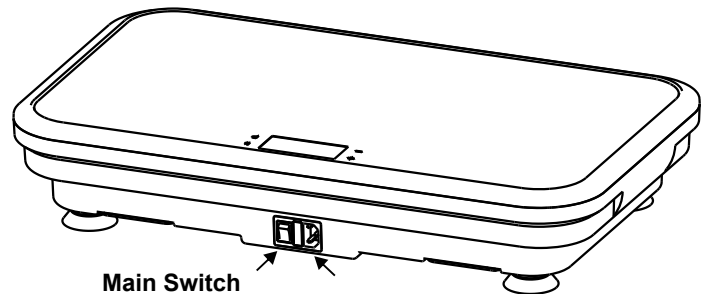

Main Switch

Electrical Connection

**CAUTION:** Never connect or remove the mains cable from the device when the cable plug is connected to an electrical socket. Always remove the electrical plug from the socket first before you connect or remove the cable from the device.

## Training Belts

The training belts included in delivery are attached to the eyelets on the vibration plate with carabiner hooks.

The eyelets are on the left and right at the back of the vibration plate. Lift the device slightly and fold out the brackets with the eyelets. Please remove the belts and fold away the brackets when not in use.

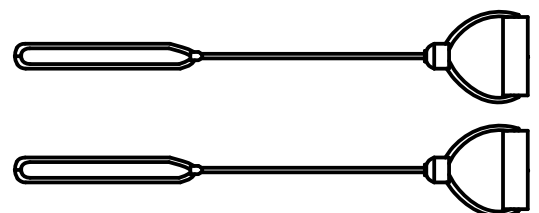

## Mains Connection

### Power Cable

Only use the power cable included in delivery to operate your training device. First, attach the connector on the power cable to the connection at the back of the device. Only then connect the mains plug on the power cable to the electrical supply socket. If you want to remove the power cable from your device, first pull the mains plug out of the electrical socket before disconnecting the power cable from the device.

### ⚠ CAUTION

Only connect your training device to grounded electrical socket installed by qualified electrician. Do not plug this device into a power strip or cable reel.

### Mains Switch

After connecting the power cable correctly, you can switch your device on and off at the main switch.

To switch on the device, press the switch into position "I".

To switch off the device, press the switch into position "0".

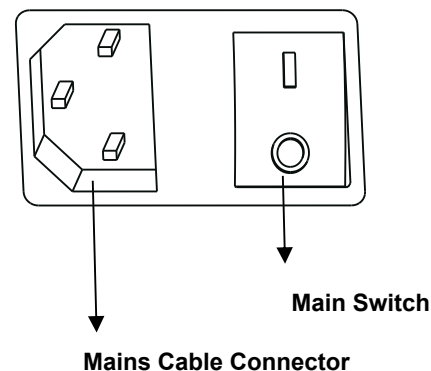

## Attaching the Training Belts

At one end of the training belts is a handle and on the other end is a carabiner hook.

On the bottom at the back of the vibration plate there are two brackets with eyelets. To attach the training belts to the vibration plate, lift the device far enough up at the back so you can pull out the two brackets. With the carabiner hook attach one training belt to each bracket on either side of the device.

Please remove the training belts and fold-in the brackets if the belts are not in use.

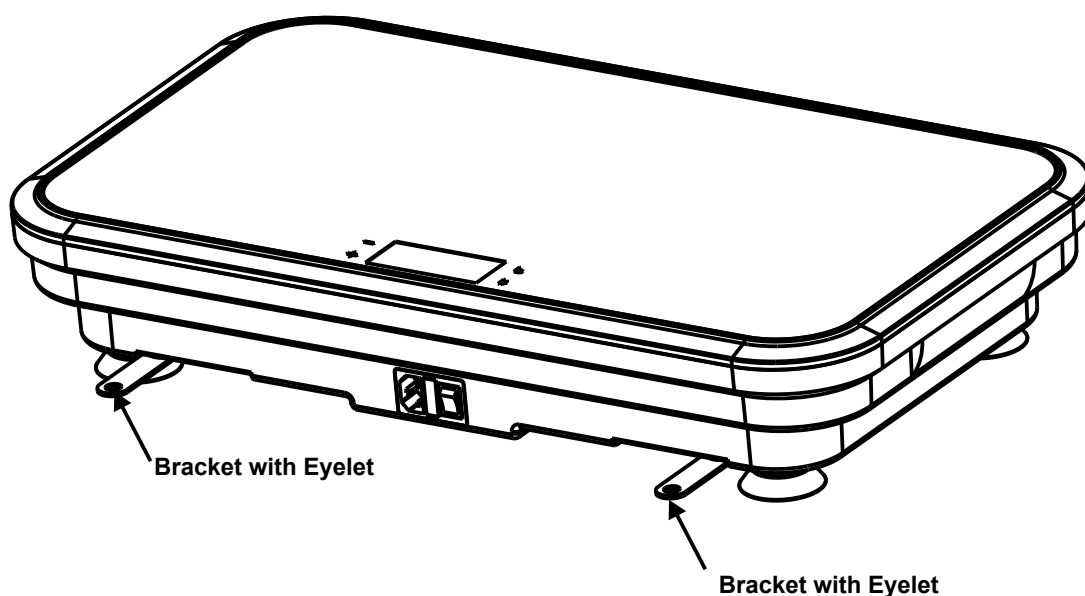

## Recommended Accessories



### MAXXUS® Vibration Plate - Floor Protection Mat

Due to its extreme density and material thickness of 1.2cm, this mat optimally dampens the vibrations and noise of the vibration plate during training. In addition, it also provides perfect protection for floors and floor coverings against damaging, scratches and soiling through body sweat.



Dimensions: 100 x 100 cm

## Operation

Please read the safety and operating instructions contained in the manual carefully before using this device. Also make sure that any third party using the device has also read and is familiar with the safety and operating instructions before they use the device.

Always connect the mains cable to the device before connecting it to an electrical socket. Switch the device on at the main switch. Before disconnecting the device from the electrical power, switch it off at the main switch first. Then remove the mains cable from the electrical socket. Only then should the mains cable be removed from the device if necessary.

### Before using the device for the first time and general information on use

1. Unpack the vibration plate.
2. Place the vibration plate on a suitable surface. Ideal for this is a solid surface such as concrete, tiles, etc. If you use the vibration plate on loose flooring such as laminate or parquet this may lead to vibrations being transferred to the flooring. Wooden floors are not at all suitable. As this vibration plate works very intensively in the higher training levels, we always recommend using a floor protection mat with a thickness of at least 1.2 cm.
3. Remove the protective foil from the training surface of the vibration plate.
4. First connect the mains cable to the vibration plate and then to a suitable electrical socket.
5. Switch on the vibration plate at the main switch on the back of the device.
6. Check if the batteries have been inserted correctly into the remote control.
7. Press the  key on the remote control to switch on the display on the vibration plate.
8. Start your training session.
9. To turn the display off again and to switch the vibration plate into standby mode, press the  key on the remote control.
10. To switch off the vibration plate completely, put the main switch on the back of the device into the "0" position.

### Note on using the remote control:

Please note that the maximum range of the remote control is 200 cm (with fully charged batteries). Always direct the remote-control transmitter towards the receiver on the vibration plate. There must be no obstacles between the transmitter and receiver. Regularly check the charge of the batteries and replace them as soon as the signal becomes weak or if the red LED no longer lights up when you press one of the keys on the remote control.

## Manual Training

### Step 1: Switching on the Device

Switch on the vibration plate at the main switch.

### Step 2: Switching on the Display

Press the POWER key on the remote control to switch on the display.

### Step 3: Total Training Time Input

When switched on the display will show the maximum training time of 10:00 minutes. By pressing the TIME key ▼ you can reduce the time in 1 minute increments. To increase the training time back up to the maximum of 10:00 minutes, press the TIME key ▲

### Step 4: Training Start

To start training press the START/STOP key.

At the end of a visual and acoustic countdown the vibration plate will start with training.

### Step 5: Changing and Adjusting the Training Level

By pressing the SPEED ▲ and SPEED ▼ you can select the required training level from 1 to 60. The current training level can be changed at any time during training. You can select the pre-set levels 20, 40, and 60 direct by pressing the quick selection key M.

### Step 6: Training End

Press the START/STOP key if you want to stop training before the training time has been reached. Otherwise, training will stop automatically once the set training time has been attained.

## Training Programs P1 - P5

### Step 1: Switching on the Device

Switch on the vibration plate at the main switch.

### Step 2: Switching on the Display

Press the POWER key on the remote control to switch on the display

### Step 3: Training Program Selection

When switched on the display will show the maximum training time of 10:00 minutes.

By pressing the P key, you can select the required training program from P1 to P5.

### Step 4: Training Start

To start training press the START/STOP key.

At the end of a visual and acoustic countdown the vibration plate will start with training.

### Step 5: Training End

Press the START/STOP key if you want to stop training before the training time has been reached. Otherwise, training will stop automatically once the set training time has been attained.

### NOTE:

Training program P1 and P5 are pre-set programs in which the training time of 10:00 minutes and the frequency cannot be changed. The programs are divided into 10 different segments of 1 minute. This makes it possible for the user to carry out the required exercise without having to adjust the plate settings every time for each new exercise.

P	S1		S2		S3		S4		S5		S6		S7		S8		S9		S10	
	Level	Hz	Level	Hz	Level	Hz	Level	Hz	Level	Hz	Level	Hz	Level	Hz	Level	Hz	Level	Hz	Level	Hz
P1	16	18.83	18	19.34	28	21.89	38	24.44	48	26.99	58	29.54	48	26.99	38	24.44	28	21.89	18	19.34
P2	20	19.85	40	24.95	60	30.04	80	35.15	99	40.00	40	24.95	99	40.00	40	24.95	99	40.00	40	24.95
P3	10	15.00	44	25.97	99	40.00	33	23.16	99	40.00	22	20.36	99	40.00	11	17.55	99	40.00	44	25.97
P4	40	24.95	26	21.38	80	35.15	99	40.00	55	28.77	75	33.87	99	40.00	11	17.55	99	40.00	70	32.59
P5	10	15.00	40	24.95	50	27.50	99	40.00	50	27.50	40	24.95	10	15.00	40	24.95	50	27.50	10	17.30

## Operation

Level	Hz
1	15
2	15,26
3	15,51
4	15,77
5	16,02
6	16,28
7	16,53
8	16,79
9	17,04
10	17,3
11	17,55
12	17,81
13	18,06
14	18,32
15	18,57
16	18,83
17	19,08
18	19,34
19	19,59
20	19,85
21	20,1
22	20,36
23	20,61
24	20,87
25	21,12
26	21,38
27	21,63
28	21,89
29	22,14
30	22,4
31	22,65
32	22,91
33	23,16

Level	Hz
34	23,42
35	23,67
36	23,93
37	24,18
38	24,44
39	24,69
40	24,95
41	25,2
42	25,46
43	25,71
44	25,97
45	26,22
46	26,48
47	26,73
48	26,99
49	27,24
50	27,5
51	27,75
52	28,01
53	28,26
54	28,52
55	28,77
56	29,03
57	29,28
58	29,54
59	29,79
60	30,04
61	30,3
62	30,55
63	30,81
64	31,06
65	31,32
66	31,57

Level	Hz
67	31,83
68	32,08
69	32,34
70	32,59
71	32,85
72	33,11
73	33,36
74	33,62
75	33,87
76	34,13
77	34,38
78	34,64
79	34,89
80	35,15
81	35,4
82	35,66
83	35,91
84	36,17
85	36,42
86	36,68
87	36,93
88	37,19
89	37,44
90	37,7
91	37,95
92	38,21
93	38,46
94	38,72
95	38,97
96	39,23
97	39,48
98	39,74
99	40



# Training

## General Information

When using the vibration plate, it is not advisable to fully straighten out any joints such as knees or arm joints. Always have your joints bent, even if you are working at a low training level.

The maximum training time (without breaks) should be between 5 to 10 minutes. Individual exercises should be a maximum of 60 seconds, or better between 30 to 45 seconds long. The breaks between individual exercises should be at least 30 to 60 seconds.

Do not train more than once a day.

Please be aware that muscles need rest in order to get stronger. You should therefore give your muscles at least 48 hours recovery time before starting your next training session.

With muscle building exercises the muscle or muscle group should be stimulated during the entire training time. This can be achieved by putting the muscle under static tension.

### Example Squats:

If you stand with fully straightened legs on the vibration plate, the vibrations will pass straight through your body to your head. If you now bend your knees into a squat which puts your muscles under tension, the vibrations will be concentrated in this area. The further you tension the muscles the more intensively the muscles will be activated by the vibrations. This principle applies to all muscle groups.

If you use the vibration plate at a low training level for massage, you should also always slightly bend your joints.

### CAUTION:

Never stand with both feet on one side of the vibration plate. This can lead to processing faults and in the worst-case, cause damage to the plate. Also, there is a risk of falling and therefore injury to the user.

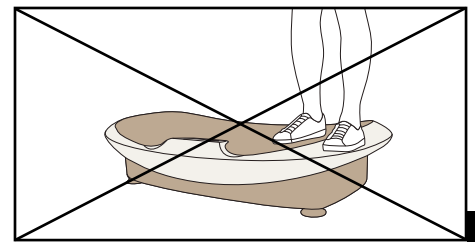

ENG

## Training Overview

In addition to the example exercises shown on the training poster, the following exercises are ideal for training and relaxing the different muscle groups:

### Standing

loosens and relaxes the muscles  
Stimulates blood circulation.

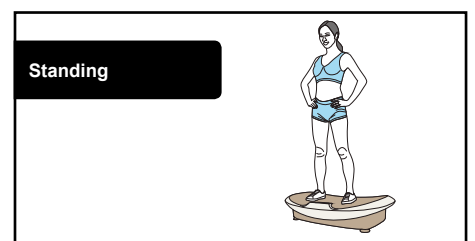

### Press-Ups

loosens and relaxes the muscles  
Trains the upper body muscles intensively  
Ensures optimum body tension.

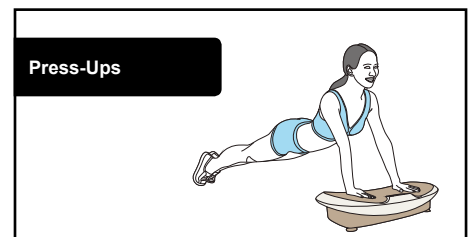

### Sitting/Stretch

Loosens and relaxes the muscles in the upper body  
and hip areas  
Trains the upper body and stomach muscles  
Ensures optimum body tension.

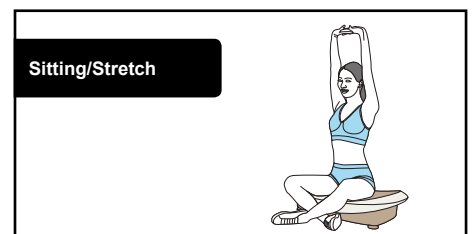

## Training

**Relax/Upper Body** Loosens and relaxes the muscles in the shoulder throat and neck areas

Light training for the stomach muscles

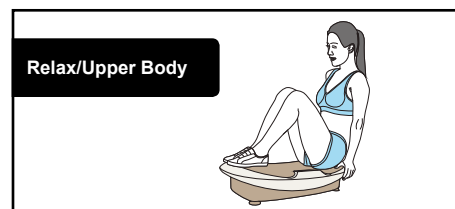

**Relax / Lower Body** Loosens and relaxes the all leg muscles and hip area  
Ideal for older users with restricted movement.

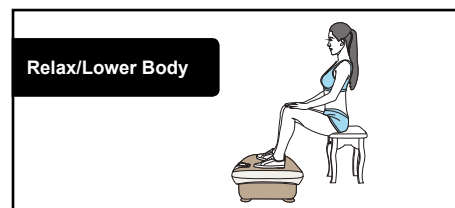

## Dynamic Exercises with Training Belts

### Side Lifts

Stand with both feet on the plate (you are free to choose the position of your feet and training speed).

Take hold of the training belts and raise both arms together straight until they are parallel out to the sides.

Then lower both arms to hang down at your sides.

Repeat this exercise slowly and smoothly.

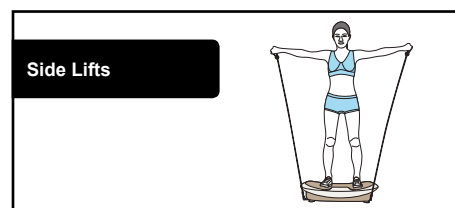

### Cross-Over Lifts

Stand with both feet on the plate (you are free to choose the position of your feet and training speed).

Take hold of the training belts and alternately raise your left and right arms to shoulder height in front of you and each time point the arm in the opposite direction across your body in front of you. Turn your body in the same direction as your arm is pointing.

Repeat this exercise slowly and smoothly.

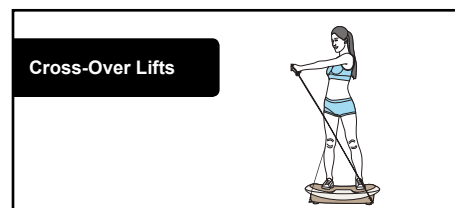

### Back Step / Biceps Curl

Stand with one foot on the plate (you are free to choose the position of your feet and training speed).

Take hold of the training belts and whilst bending the knee of the leg which is still on the floor. Bend your arms and raise your hands up towards your chin keeping your upper arms flat against your body. Whilst straightening your bent knee and coming up again with your body, lower your hands back down in front of you. Repeat this exercise slowly and smoothly and change legs to bend the other knee at half time.

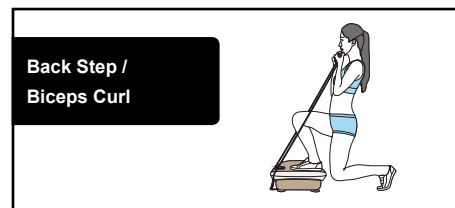

### Squat / Front Lift

Stand with both feet on the plate (you are free to choose the position of your feet and training speed).

Take hold of the training belts. Whilst doing a squat, raise both arms to be level with your chin and outstretched to the front. Whilst straightening your body again, lower your arms back down again.

Repeat this exercise slowly and smoothly.

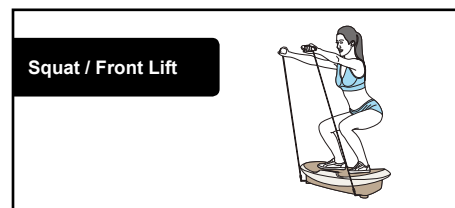

### Standing Biceps Curl

Stand with both feet on the plate (you are free to choose the position of your feet and training speed).

Take hold of the training belts and bend your arms to bring your hands up to your shoulders and keeping your upper arms flat against your body. Then bring the lower part of your arm back down so your arms are pointing down again.

As an alternative, you can supplement this exercise with a squat.

Repeat this exercise slowly and smoothly.

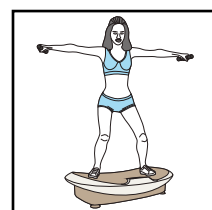
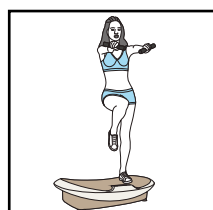
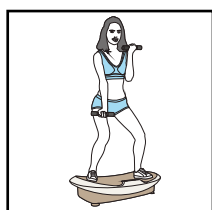
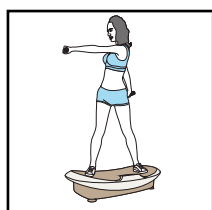
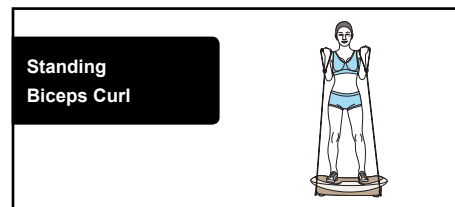

Alternatively, you can do these individual exercises without using the training belts but using weights such as dumbbells, filled water bottles etc for example (these accessories are not included in delivery).

## Technical Information

### Changing the Batteries in the Remote Control

1. Remove the cover on the battery compartment at back of the remote control. To do this put your thumb on the ribbed and slightly indented markings on the top of the battery compartment cover and push this back whilst pushing gently down with your thumb.
2. Change the batteries. The remote control needs 2 type AAA Micro 1.5V batteries.
3. Replace the cover to the battery compartment.

## Cleaning & Maintenance

### CAUTION:

**Before you perform any care, cleaning, maintenance, repair or similar work on your training device, it must be completely disconnected from the mains. This is only the case if the plug is removed from the electrical power supply socket and the mains cable is disconnected from the device. When doing this always remove the plug from the socket first and then disconnect the mains cable from the device. The mains cable may only be reconnected to the device and then plugged into the electrical socket when all work is fully completed, and the device is restored to perfectly functioning condition.**

### Cleaning

Clean your device after each training session using a damp cloth and soap. Never use solvents for this purpose. Regular cleaning contributes significantly to the preservation and life service of your training device.

Damage caused by body perspiration or other liquids will not under any circumstances be covered by the warranty. During training make sure that no liquids get into contact with the device or get into the computer.

## Maintenance

### Checking the Fixing Materials

Make regular checks to ensure that fixing materials such as screws, nuts etc are tightened firmly. If not, tighten them wherever necessary.

ENG

## Location and Storage

This training device was exclusively designed for use indoor dry and temperate areas.

Use or storage in damp or wet areas, such as sauna, swimming pool, etc. and in outdoor areas, like balcony, terrace, garden, garage, etc. is not permitted.

In these locations the prevailing high humidity and low temperatures may lead to defects in the electronics, corrosion and rust. No warranty claims for damages of this kind will be accepted under the warranty.

Please choose a dry, well-tempered and completely flat location for training and storage of this device. For training, locate the device in an area where the walls and furniture are at least 1 meter away from the device.

For your own safety and comfort, make sure that the training area is adequately ventilated during exercise, to allow for optimal oxygenation.

Before using your training device after a long period of non-use, make sure that all fixings are secured tightly. If you have stored the product for a long time in a cold storage location or otherwise have stored it in a non-temperate place, leave the device for at least one hour at room temperature before switching it on again.

### LCD Display

**Display of:**

Time  
Training Level  
Program

**Technical Details**

Training Level: 60 Levels  
Time Range: Maximum 10 Minutes  
Time Adjustment: in 1-minute increments  
Motor Type: DC Motor  
Performance: 50.0 Watt  
Training Surface: ca. 59 x 32,5 cm  
Dimensions (BxWxH): approximately 62.5 x 37 x 12 cm  
Total Weight: approximately 13.5kg  
Maximum User Weight: 100 kg  
Input Selection: via Keypad or Remote Control  
Power Supply: 220-230V - 50Hz  
Battery (Remote Control): 2x AAA Micro 1.5V Batteries  
Noise Level: ≤57dB

**Area of Application:** Home Use

## Error Messages

Error	Trouble Shooting
The vibration plate does not switch on	Check that the mains cable is properly connected to the vibration plate and correctly plugged in at the socket. Check the mains cable for any damage.
The remote control does not function	Check that the batteries are charged. Make sure that the batteries have been put in correctly. Make sure that the maximum 2 meter range has not been exceeded and ensure that there are no obstacles between the remote control and the display receiver. Make sure that you are pointing the remote control directly at the receiver.
The vibration plate no longer responds to commands	Switch off the device and wait for 20 seconds before switching it on again.

## Disposal



**European Disposal Regulations 2002/96/EG**

Do not dispose your training device in the normal household rubbish.  
Dispose the device at a communal waste disposal facility or at a registered waste disposal company.  
Observe current regulations which apply accordingly. If in doubt seek advice from your local government office or county council as to where you can dispose of the device properly and in an environmentally sound manner.

**Batteries / Rechargeable Batteries**

Batteries and rechargeable batteries should never be disposed of in the household rubbish.  
Please be aware that all batteries can contain toxic substances and all consumers are obliged by law to dispose these at an appropriate collection point either at your local government office, county council or retail outlet.  
If in doubt seek advice from your local government office or county council as to where you can dispose batteries properly and in an environmentally sound manner. Only dispose of batteries when they are empty.

# Exploded Drawing & Parts List

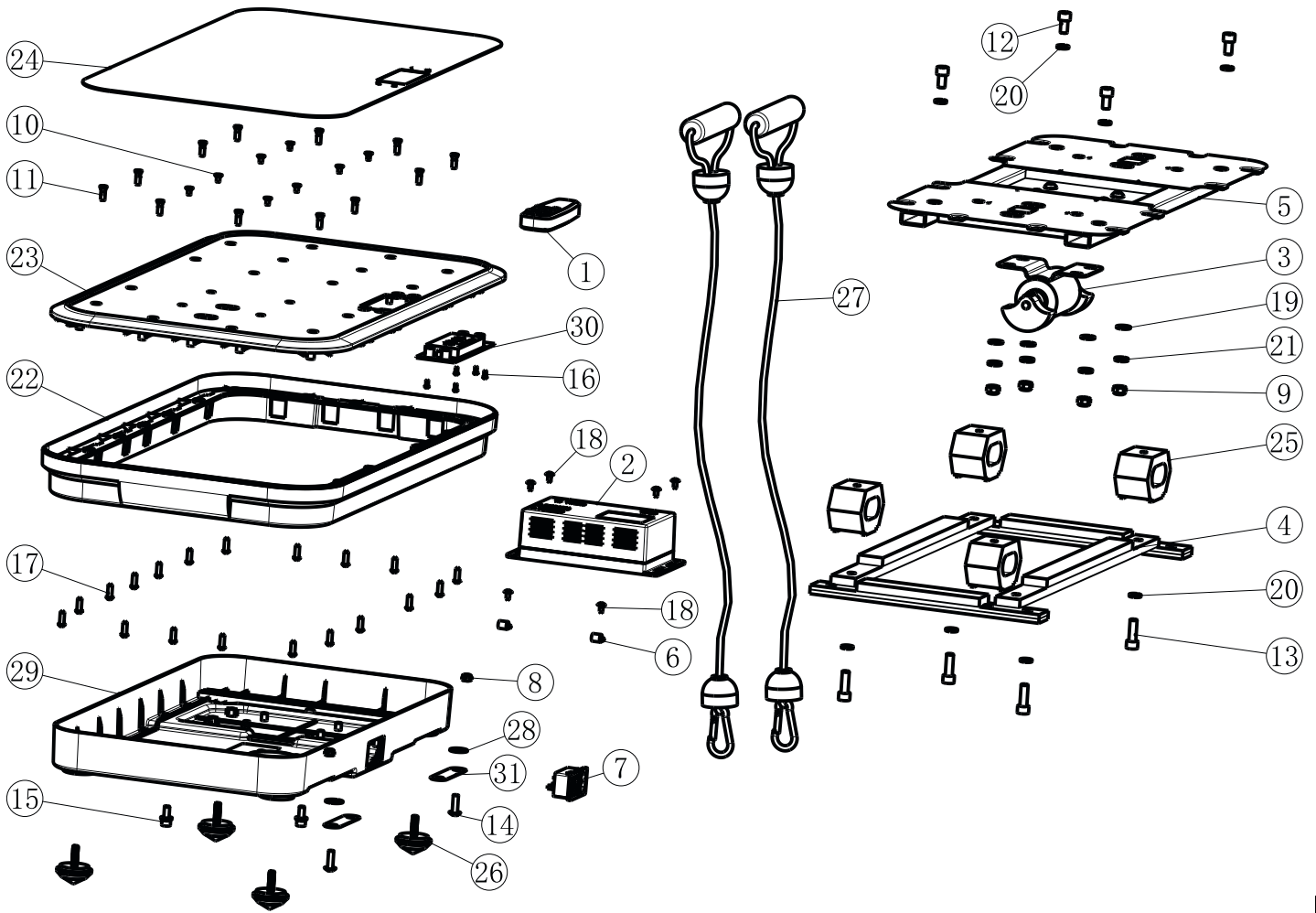

ENG

No.	Description	Qty
1	Remote control	1 Pcs
2	Control unit box 100-240VAC full voltage	1 Set
3	Motor system 24VDC	1 Set
4	Bottom steel frame	1 Pcs
5	Upper steel frame	1 Pcs
6	Wire clip 5/16"	2 Pcs
7	Power switch 31x50 with light	1 Set
8	Locknut M6	2 Pcs
9	Locknut M8	4 Pcs
10	Cross groove countersunk head screw M4x8	8 Pcs
11	Cross groove countersunk head screw M5x12	12 Pcs
12	Hexagon socket head screw M8x15	4 Pcs
13	Hexagon socket head screw M8x25	4 Pcs
14	Cross large flat head screw M6x20	2 Pcs
15	Hexagon combination screw M6x16	2 Pcs
16	Cross groove pan head self tapping screw ST3x8	5 Pcs

No.	Description	Qty
17	Cross groove pan head self tapping screw ST5x16	19 Pcs
18	Cross groove big pan head self tapping screw ST4x10	6 Pcs
19	Flat washer $\Phi 8.4 \times \Phi 16.0 \times T1.5$	4 Pcs
20	Spring washer $\Phi 8.4 \times \Phi 13.5 \times T2.5$	8 Pcs
21	Cushion $\Phi 8.4 \times \Phi 15 \times T2.5$	4 Pcs
22	Middle cover	1 Pcs
23	Upper cover	1 Pcs
24	Pedal mat 1.5mm	1 Pcs
25	Ruuber Pad	4 Pcs
26	Conical Pad $\Phi 40 \times 20 \times M6 \times 23$	4 Pcs
27	Spring rope	2 Pcs
28	Soft flat cushion $\Phi 20 \times \Phi 10.5 \times 1.5$	2 Pcs
29	Bottom cover	1 Pcs
30	PCB of display	1 Pcs
31	fixation plate of rope 80*20*2.0T	2 Pcs

## Warranty \*

For MAXXUS® Support Team to help you as quickly as possible with service, we will require certain information about your fitness device and about you. To find the exact spare parts required, we will need the product name, date of purchase and serial number.

If necessary, please fill out completely the Repairs Contract/Damage Report form attached to this User Manual and send it to us by post or by fax.

### Areas of Application & Warranty Periods

Depending on the model, fitness devices from MAXXUS® are suitable for use in different areas. Find the appropriate area of use for your fitness device from the "Technical Data" in this User Manual.

#### Home Use:

Exclusively for private use

Warranty Period: 2 Years

#### Semi-Professional Use:

Use under instruction in hotels, physiotherapy practices, etc.

Use in a fitness studio or similar establishment is hereby excluded!

Warranty Period: 1 Year

#### Professional Use:

Use in a fitness studio or similar establishment under supervision by trained personnel.

Warranty Period: 1 Year

Use of your training device in an area which is not suitable for your device will cause immediate expiry of its guarantee and cancel your right to claim warranty!

Sole private use and warranty period of 2 years assumes that the purchase invoice is made out to the end user.

### Proof of Purchase and Serial Number

To claim your right to service works within the warranty period we will in each case require proof of purchase. Keep your proof or purchase or purchase invoice in a safe place and in warranty cases send us a copy together with your Repairs Contract/Damage Notification. This will ensure that we can process the service work as quickly as possible. So that we can identify which model version requires to be serviced correctly, we will require; Product Name, Serial Number and Date of Purchase.

### Terms and Conditions of Warranty:

The warranty period for your training device starts on the date of purchase and applies solely to products which were purchased directly from the MAXXUS Group GmbH & Co KG or one of the MAXXUS Group GmbH & Co KG direct and authorised distribution partners.

The warranty covers defects caused by production or material faults and only apply to devices purchased in Germany. The warranty does not apply to damages or defects caused by culpable improper use, negligent or purposeful destruction, lack or failure to carry out maintenance and/or cleaning measures, force majeure, operational causes and to normal wear and tear, damages caused by penetration of liquids, damage caused by repairs or modifications made with spare parts from a different supplier. The warranty also does not apply for damages due to faulty assembly or damages which occur because of faulty assembly. Certain component parts will wear out during use or from normal wear and tear. This includes for example:

- Ball bearings
- Bearing bushings
- Bearings
- Drive belts
- Switches and push-buttons
- Treadmill belts (bands)
- Treadmill decks (running deck)
- Rollers

Signs of wear and tear on wearing parts are not items covered under the warranty.

### Service Outside the Warranty and Ordering Spare Parts

The MAXXUS® Service Team is happy to be of assistance to help solve any problems with faults which may arise following expiry of the warranty period, or in cases of defects arising which are not covered by the warranty.

In this case please contact us by email direct to:

**service@maxxus.de**

Orders for Spare Parts or Worn Parts should be sent along with information on the Product Name, spare part description and number and the quantity required to:

**spareparts@maxxus.de**

Please be informed that additional fixing materials such as screws, bolts, washers etc are not included in the scope of delivery for individual spare parts. These should be ordered separately.

\*Version: June/2016

**LIFEPLATE®** Repair order / damage report**Device Details**Product Name: **Lifeplate® 2.0**Product Group: **Vibration Plates**

Serial Number: \_\_\_\_\_

Invoice Number: \_\_\_\_\_

Date of Purchase: \_\_\_\_\_

Where Purchased: \_\_\_\_\_

Accessories: \_\_\_\_\_

**Type of Use:** Private Use Commercial Use**Personal Details**

Company: \_\_\_\_\_

Contact Person: \_\_\_\_\_

First Name: \_\_\_\_\_

Second Name: \_\_\_\_\_

Street: \_\_\_\_\_

House Number: \_\_\_\_\_

Post Code / Town/City: \_\_\_\_\_

Country: \_\_\_\_\_

E-Mail: \_\_\_\_\_

Tel.No.: \_\_\_\_\_

Fax. No.\*: \_\_\_\_\_

Mobile No.\*: \_\_\_\_\_

\* The fields marked with an asterisk are optional. The remaining fields are mandatory fields that must be completed.

**Fault Description**

Please enter a short description of the error as precisely as possible below:

(For example, when, where and how does the error occur? Frequency, after which period, at what Use, etc ....)

ENG

 A copy of the proof of purchase / invoice / receipt is attached. I accept the General Terms and Conditions of MAXXUS® Group GmbH & Co. KG.

I hereby instruct the company MAXXUS® Group GmbH & Co. KG to repair the above defects. In Warranty cases I will not be charged for the cost. The costs for repairs which are excluded from liability for defects in quality will be charged to me and must be settled immediately. In cases of repairs carried out on site, our staff are entitled to collect payment. This agreement is confirmed with here with my signature.

_____	_____	_____
Date	Location	Signature

Please be aware that contracts can only be processed if this form has been completed in full. Be sure to attach a copy of your purchase invoice. Send the fully completed Repairs Contract / Notification of Damage Claim to:

**Post\***: Maxxus Group GmbH & Co KG, Service Department, Zeppelinstr. 2, 64331 Weiterstadt**Fax**: +49 (0) 6151 39735 400**E-Mail\*\***: customerservice@maxxus.de

\* Please stamp with sufficient postage – letters which are not sent postage paid will unfortunately not be accepted.

\*\* Submission by E-Mail is only possible as a scanned document with original signature.

# LIFEPLATE®

**vibration technology**

**Maxxus Group GmbH & Co. KG**  
Zeppelinstr. 2  
D-64331 Weiterstadt  
Germany  
E-Mail: [info@maxxus.de](mailto:info@maxxus.de)  
[www.maxxus.de](http://www.maxxus.de)