

**MAXXUS<sup>®</sup>**

**CX 6.1**  
Cross Trainer

ENG

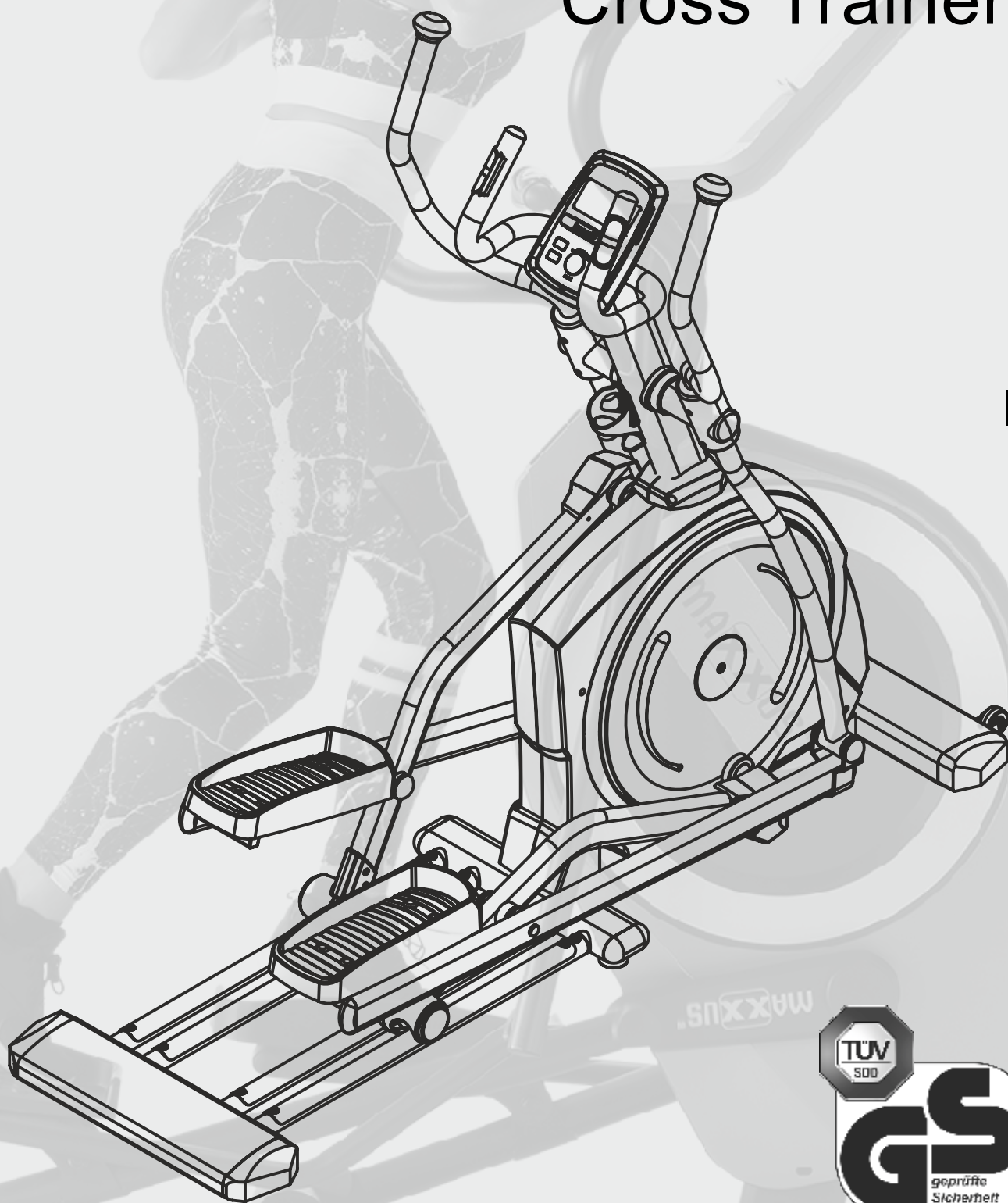

## Index

Index	2
Safety Instructions	3
Overall View of the Device	4
Scope of Delivery	4 – 5
Assembly	5 – 12
Levelling the Device	13
Transport	13
Safety Distance	14
Location & Storage	14
Maintenance & Care	14
Mains Connection	15
Cockpit	16 – 23
Pulse & Heart Rate	24 – 25
Training Recommendations	26 – 27
Technical Details	28
Disposal	28
Exploded Drawing	29
Spare Parts List	30
FAQ	31
Recommended Accessories	31
Warranty	34
Service Contract	35

© 2019 MAXXUS Group GmbH & Co. KG  
All rights reserved / All rights reserved

This publication may not be reproduced, stored in a retrieval system, or transmitted in whole or in part, in any form or by any means, electronic, mechanical, photocopying, recording, or otherwise without the prior written permission of Maxxus Group GmbH & Co. KG.

Errors, colour and technical modification subject to change, reproduction as well as electronic duplication only with written permission of MAXX-US Group GmbH & Co. KG.

Before you start exercising, be sure to read the entire user guide, especially the safety information, the maintenance & cleaning information and the training information. Take care too that everyone who uses this training device is also familiar with this information and observes it.

Be sure to carefully follow the maintenance and safety instructions in this manual.

This training device may only be used for its specific purpose. Improper use may present a risk of accidents, damage to health or damage to the exercise device. No liability whatsoever is accepted by the distributor for injury or damage caused by improper use.

#### **Power connection (only applies to devices with an external electrical connection)**

- A mains voltage of 220-230V is required for the operation of the device.
- The exerciser may only be connected to a professionally installed, earthed, 16 A, fused single socket with the mains cable supplied.
- The training device is switched on and off only using the ON / OFF switch.
- Always disconnect the power plug from the power outlet when moving the exerciser.
- Before carrying out any cleaning, maintenance or other work, always disconnect the mains plug from the socket.
- When connecting the mains plug, do not use socket strips or cable reels.
- If an extension cable is required, then it must comply with DIN standards, VDE regulations and guidelines, technical rules issued by other European Union member states or other states which are party to the Agreement on the European Economic Area.
- Always lay the power cord in such a way that it can neither be damaged nor is a tripping hazard.
- In operating or standby mode, electrical devices such as mobile phones, PCs, Televisions (LCD, plasma, tube, etc.), game consoles etc. will emit electro-magnetic radiation. For this reason, all these types of devices should be kept away from your training device as they could lead to malfunction, disturbances or false outputs being shown in heart rate measurements.

#### **Training environment**

- Select a suitable space for your training device to provide an optimum amount of free space and highest level of safety. You should leave a free space of at least 100 cm in front of and behind the device and a minimum of 100 cm to each side of the training device.
- Ensure good ventilation and that optimal oxygen is available during exercise. Avoid draughts.
- Your exercise equipment is not suitable for outdoor use, so storage and training is only possible in temperate, clean dry rooms.
- Do not operate or store your training device in wet areas, such as swimming pools, saunas, etc.
- Make sure that your exercise equipment is always mounted on a level clean surface is. Unevenness in the ground must be removed or compensated.
- To protect delicate floors, such as wood, lamina, tiles, etc. and from damage such as scratches, it is recommended to put a floor protection (carpet piece, mat, etc.) permanently under the device. Make sure that the pad is secured against slipping.
- Do not place the exerciser on pale or white carpets, as the feet of the appliance may cause marks.
- Make sure that your exercise equipment, including the power cord, does not come into contact with hot objects and there is a sufficient safety distance from any heat source, such as radiators, stoves, open fireplaces, etc.

ENG

#### **Personal safety instructions for training**

- Remove the batteries or mains cable (if present) when the training device is not in use to avoid inappropriate or uncontrolled use by any other third party, e.g. children
- You should make a health check with your doctor before your first workout.
- If you feel any physical discomfort or experience breathing problems, stop training immediately.- Always start your workouts with a light load and increase it during the course of your workout evenly and gently. Reduce the load towards the end of your training session.
- Be sure to wear suitable sportswear and sports shoes during exercise. Note that loose clothing can get caught in the running belt or rollers during exercise.
- Your exercise equipment can only be used by one person at a time.
- Check whether your device is in perfect condition before every training session. Never use your exerciser if it has any faults or defects.
- Independent repair work can only be done after agreement and approval from our service department has been received. Only original spare parts may be used.
- Your exercise equipment must be cleaned after each use. In particular, remove all residues caused by body perspiration or other liquids.
- Always make sure that liquids (drinks, body sweats, etc.) never enter the vibrating plate or penetrate the cockpit, as this leads to corrosion and damage to the mechanical and electronic components.
- Your exercise equipment is not suitable for use by children.
- During training, third parties - especially children and animals - must have a sufficient safety zone.
- Before any training, check whether there are objects under your training device and remove them. Never exercise with your exerciser when there are objects underneath.
- Always make sure that your exerciser is not misused by children as a toy or climbing equipment.
- Make sure that you and third parties never bring body parts close to moving mechanisms.

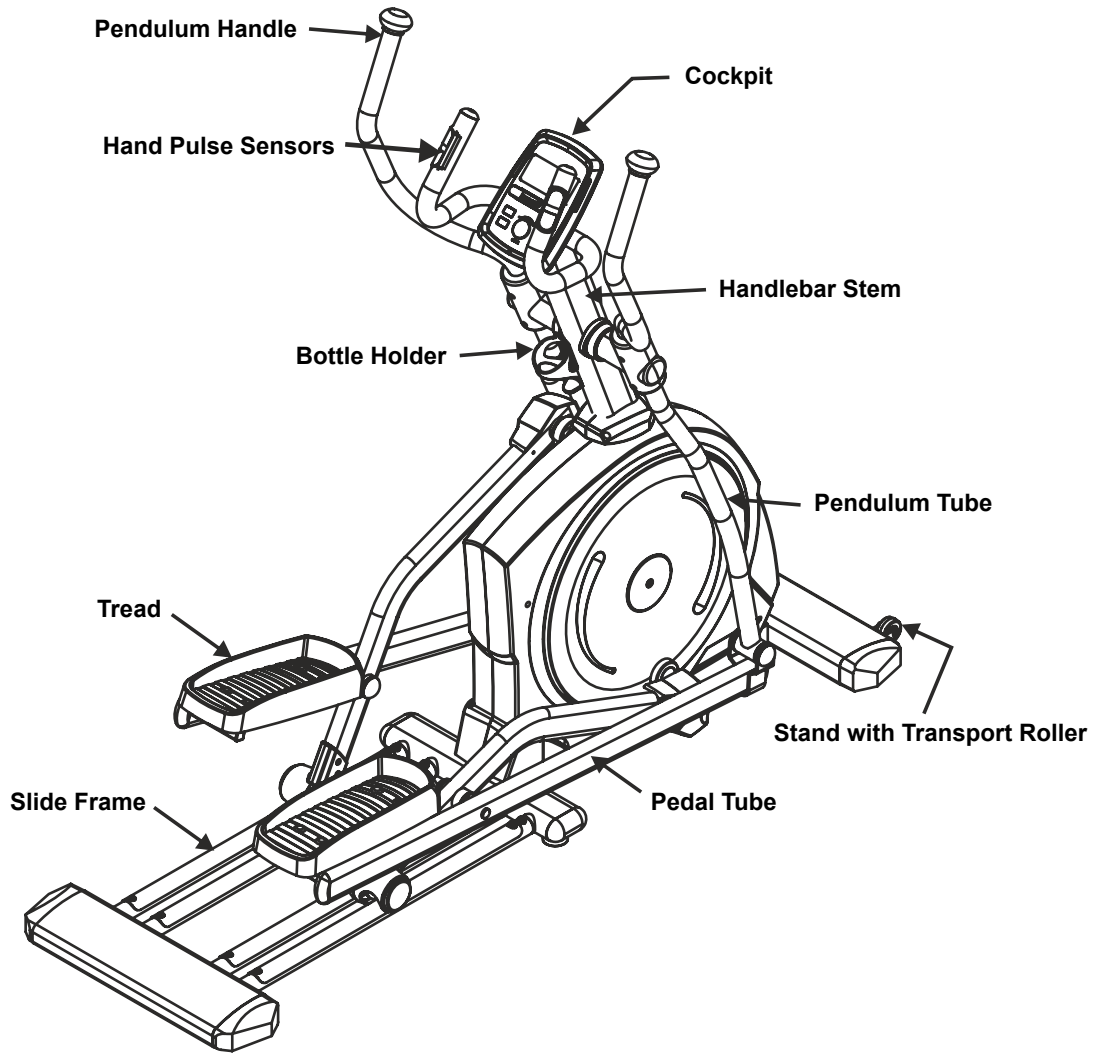

The construction of this training device is based on state-of-the-art technology and highest modern technical safety standards. This training device is to be used by adults only! Extreme misuse and/or unplanned training can cause damage to your health!

## Overall View of the Device





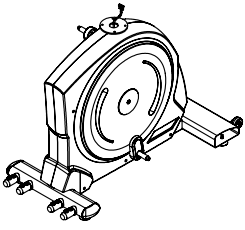
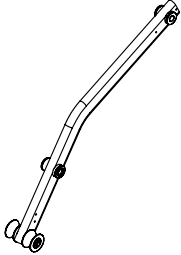
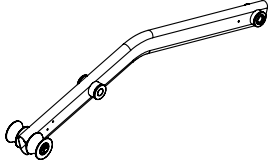
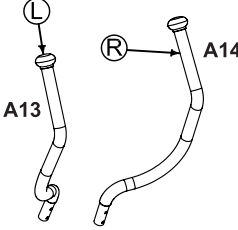
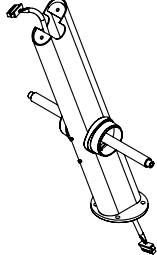
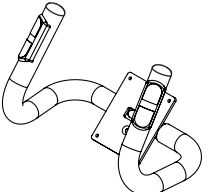
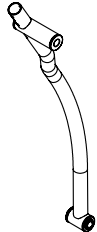

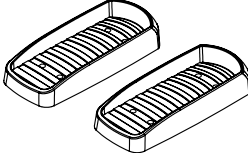
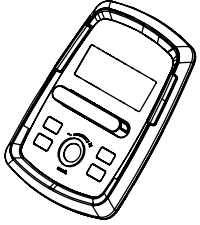
## Scope of Delivery

### Contents – Box 1

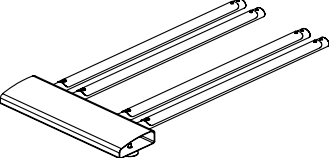
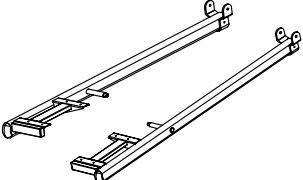
				
<b>A01</b> Base Frame	<b>A07</b> Guide Tube, left	<b>A08</b> Guide Tube, right	<b>A13/A14</b> Pendulum Handlebars	<b>A02</b> Handlebar Stem
				
<b>A15</b> Handlebars	<b>A03</b> Pendulum Tube, left	<b>A04</b> Pendulum Tube, right	<b>C12</b> Treads	<b>D02</b> Cockpit

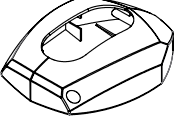
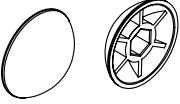
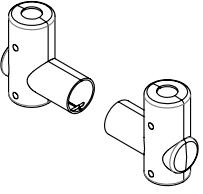
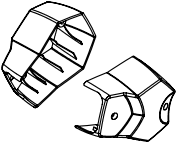
## Contents – Box 2

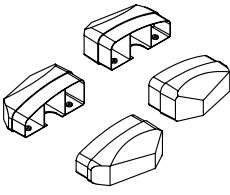
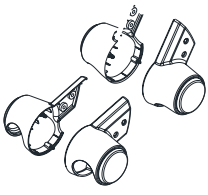
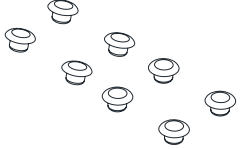
			
<b>Slide Frame</b>	<b>A05/A06 Pedal Tube, left / right</b>	<b>D08 Mains Adapter</b>	<b>C07/C08 Handlebar Stem Cover</b>
			
<b>C11 Screw Cover, round</b>	<b>C17/C18 Pendulum Tube Covers</b>	<b>C21 Guide Tube Covers</b>	<b>C27 Bottle Holder</b>
			
<b>C28/C29 End Covers for Stand</b>	<b>C32/C33 Roller Covers</b>	<b>C34 Cover plugs for Treads</b>	

ENG

## Assembly





Carefully unpack all items from the delivery two people are required as some parts of your exercise equipment are bulky and heavy.

Check that all of the fastening materials (screws, nuts, etc.) and components are complete before the individual assembly steps.

Carefully carry out the installation as damage or defects that have arisen due to assembly errors are in not covered by the warranty or guarantee. Read the instructions carefully before starting, follow the sequence of installation steps exactly and follow the instructions of the individual assembly steps. Pay particular attention to your personal safety during assembly. Wear suitable work gloves, have a second person assist you with heavy and bulky components, and secure moving components so that no parts of the body can become trapped during assembly. The installation of the training device must be carried out competent adults.

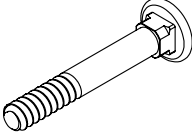
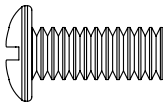
Carry out the installation of your exercise equipment in a location that is level, clean and free from obstructions. Carry out the assembly with 2 persons. Only start training after completely finishing the assembly of your training device.

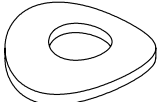
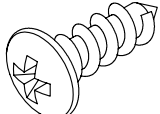
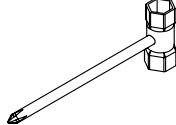
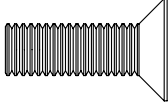
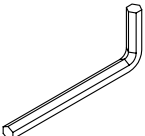
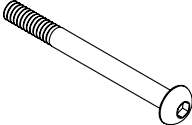
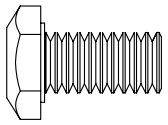
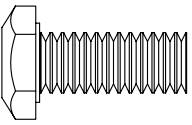
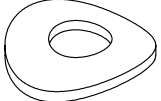
## Assembly

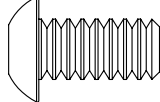
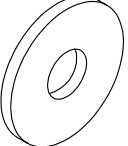
			
<b>1A Carriage bolt (B28) M8x50 - 4 pieces</b>	<b>2A Button head screw (B23) M6x15 - 8 pieces</b>	<b>3A Locknut (B29) M8 - 4 pieces</b>	<b>4A Curved washer (B30) M8x20x1.5T - 4 pieces</b>
			
<b>5A Pan head screw (B21) M5x16 - 22 pieces</b>	<b>6A Wrench/screwdriver</b>	<b>7A Allen screw (B19) M8x25 - 2 pieces</b>	<b>9A Allen key M5 - 1 piece</b>
			
<b>1B Allen screw (B24) M8x92 - 2 pieces</b>	<b>2B Hex bolt (B32) M8x16 - 6 pieces</b>	<b>3B Hex bolt (B14) M8x20 - 4 pieces</b>	<b>4B Curved washer (B30) M8x20x1.5T - 8 pieces</b>
			
<b>5B Locknut (B29) M8 - 2 pieces</b>	<b>6B Allen screw (B13) M8x16 - 8 pieces</b>	<b>7B Washer (B33) Ø5/16"xØ20x2.0T - 8 pieces</b>	

Your own tools can be used instead of or in addition to the tools included in delivery. Make sure that any tools used are suitable and an accurate fit!

### Step 1: Assembling the Slide Frame

Attach the slide frame to the rear mounts on the base frame using eight Allen screws M8x16 (6B) and eight curved washers Ø20xØ8x1.5T (4B)

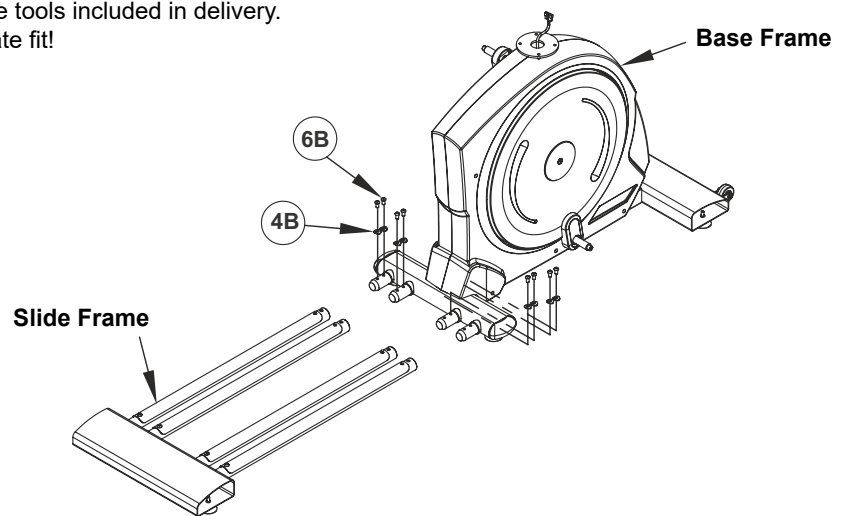

### Step 2: Assembling the End Covers

Fit the end covers (C28/C29) onto the openings on each end of the front and rear stands.

The caps should be fitted as follows:

**Front Stand with Transport Rollers**  
End cap C29 - left / End cap C28 - right

**Rear Stand**  
End cap C28 - left / End cap C29 - right

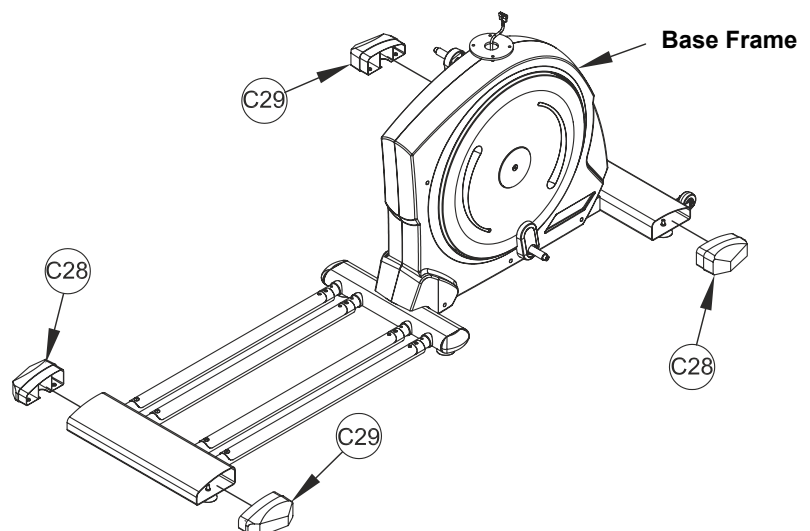

### Step 3: Assemble the Handlebar Stem

Connect the cable (D04) protruding from the handlebar shaft (A02) to the cable protruding from the base frame (A01).

Attach the handlebar stem (A02) to the base frame with four hexagon head screws M8x20 (3B).

**⚠ CAUTION:**

Make sure that you do not crush or damage the cables (D04 / D05) when installing the handlebar stem.

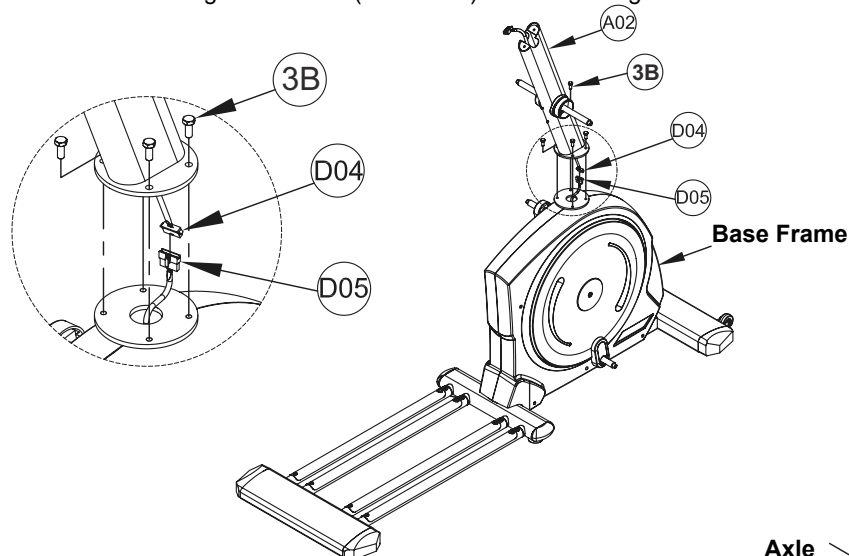

### Step 4: Greasing the Axles

Grease the axles shown in the drawing on the handlebar stem (A02) and on the base frame (A01) using the lubricant supplied or any other commercially available multi-purpose grease.

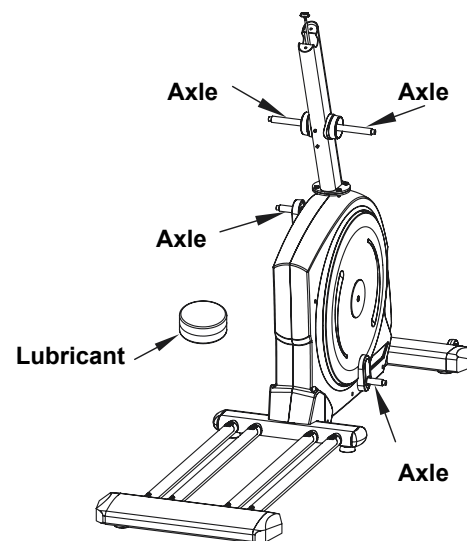

ENG

### Step 5 Assembling the Pendulum, Pedal & Guide Tubes

#### Step 5.1: Assembling the Pendulum Tubes to the Pedal Tubes

Connect the lower mount on the right pendulum tube (A04) to the front mount on the right pedal tube (A06) using an Allen screw M8x92 (1B), a washer 5x16" (7B) and a locknut M8 (5B). This connection is the articulated joint.

**⚠ CAUTION:**

Do not tighten locknut M8 (5B) too tight. Check that the nut is secure but that it still allows the articulated joint to move easily.

Repeat the same procedure with the left pendulum tube (A03) and left pedal tube (A05).

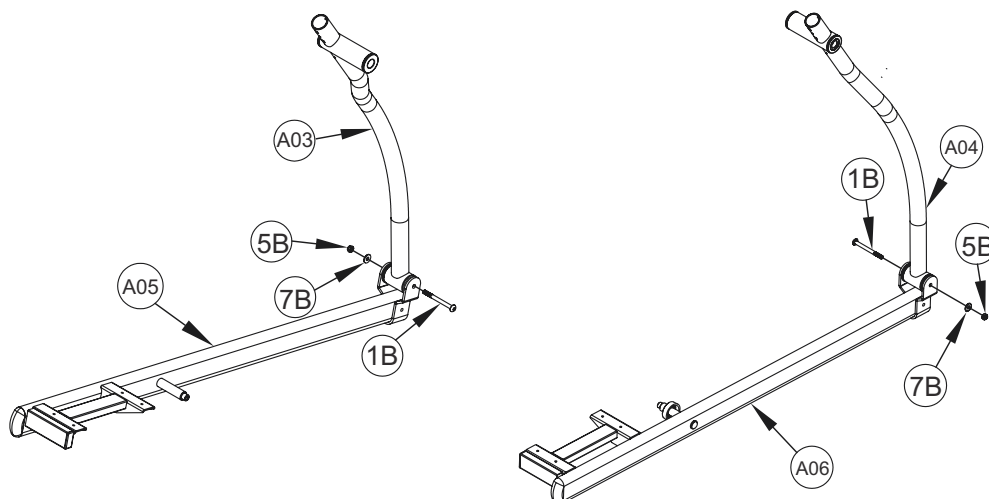

**Step 5.2: Assembling the Guide Tubes**

Slide the front mount of the right guide tube (A08) onto the small axle on the right disc drive of the base frame and place the rollers on each side of the right track on the slide frame. Fix the right guide tube (A08) with a hex bolt M8x16 (B32) and a washer 5/16" (B32).

Repeat with the left guide tube (A07)

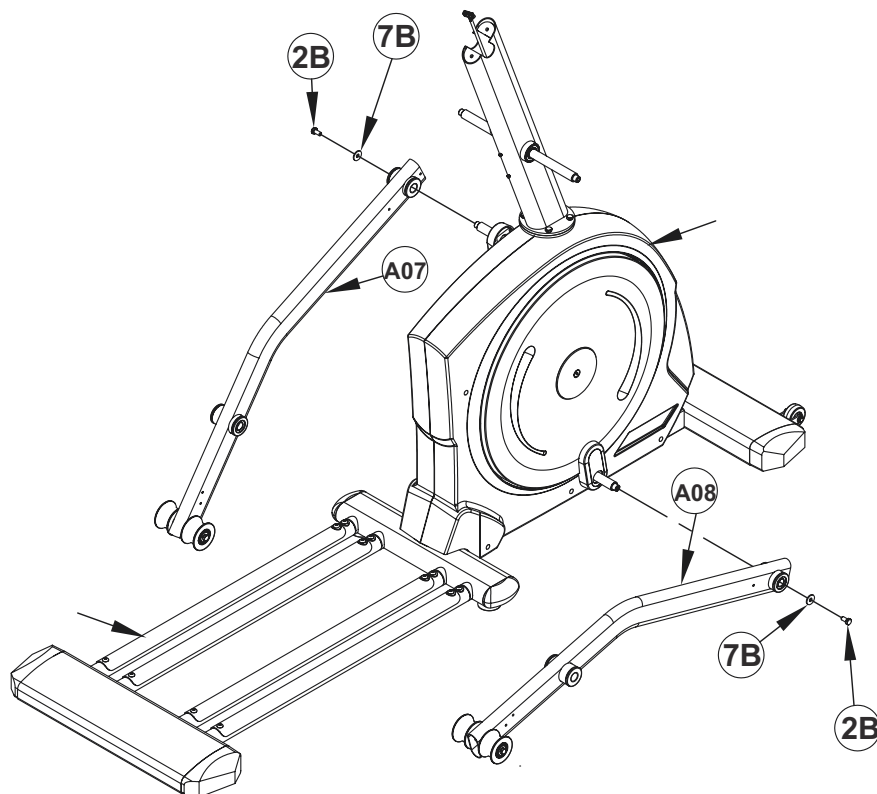

**Step 5.3: Assembling the Pendulum Tubes and Pedal Tubes**

Take the right pendulum and pedal tubes (A04/A06) connected in Step 5.1. Place the guide bush of pendulum tube (A04) onto the right transverse axle of the handlebar stem (A02) and the rear axle of the pedal tube (A06) on to the guide bush on the right guide tube (A08).

**⚠ CAUTION:**

When inserting the pendulum tube (A04), make sure that the transverse axle of the handlebar stem (A02) is centered – see Fig. 1

Fix the pedal tube with a hex bolt M8x16 (2B) and a washer 5/16" (7B). Also fix guide tube (A06) with a hex bolt M8x16 (2B) and a washer 5/16" (7B). Finally push a round screw cover (C1) over the hex bolt M8x16 (2B).

Repeat the same procedure with left pendulum and pedal tubes (A03/A05)

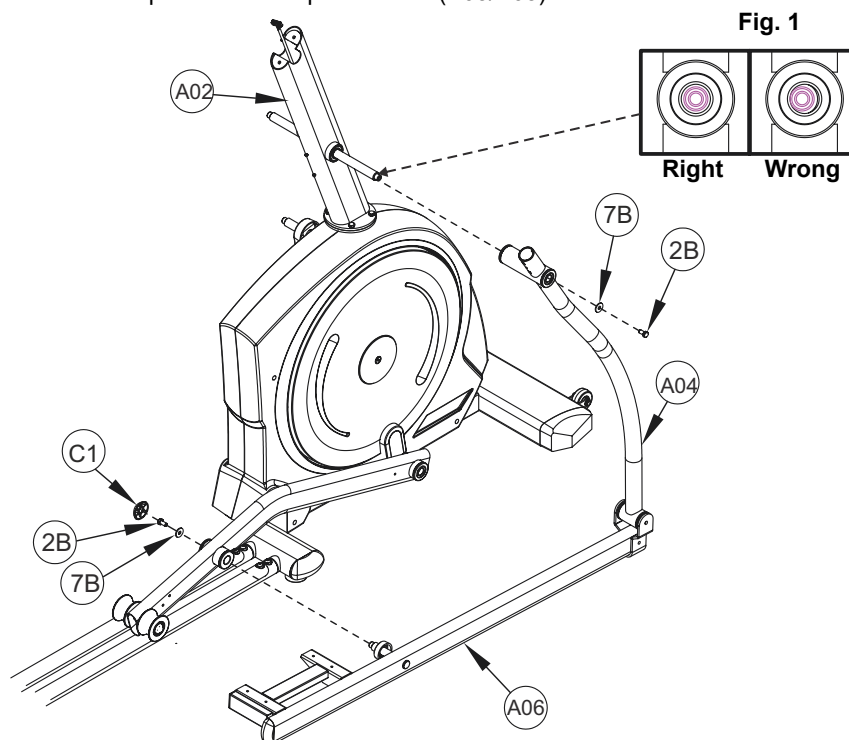



### Step 6: Assembling the Guide Tube Covers

Fix the guide tube cover (C21) with two pan head screws (5A) at the front of the right guide tube. Repeat this procedure with the left guide tube.

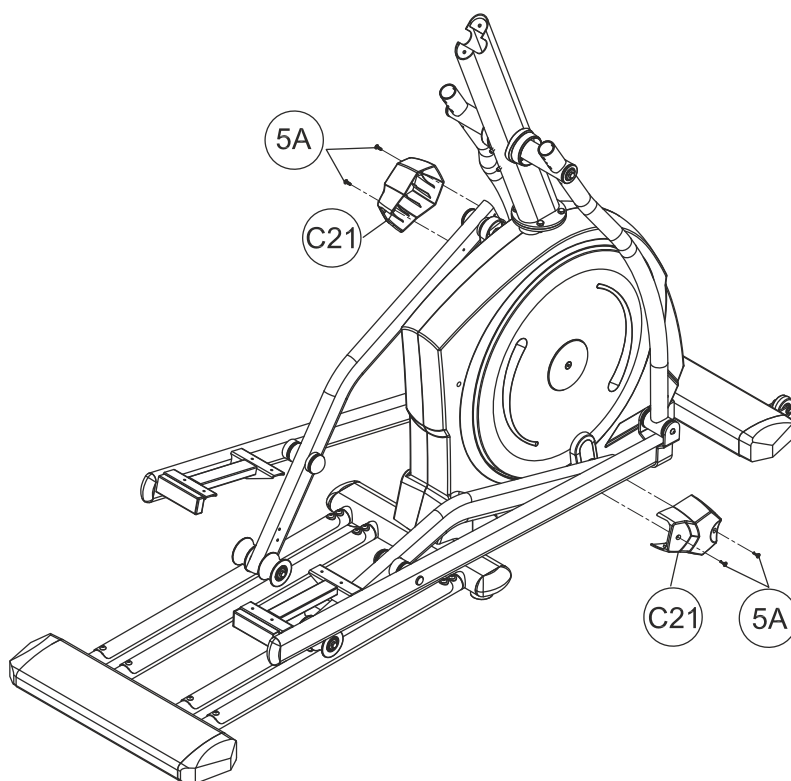

### Step 7: Assembling the Roller Covers

Fix the two roller covers (C32, left/C33, right) using four pan head screws (5A) to the right guide tube just above the roller. Repeat the same procedure with the left guide tube.

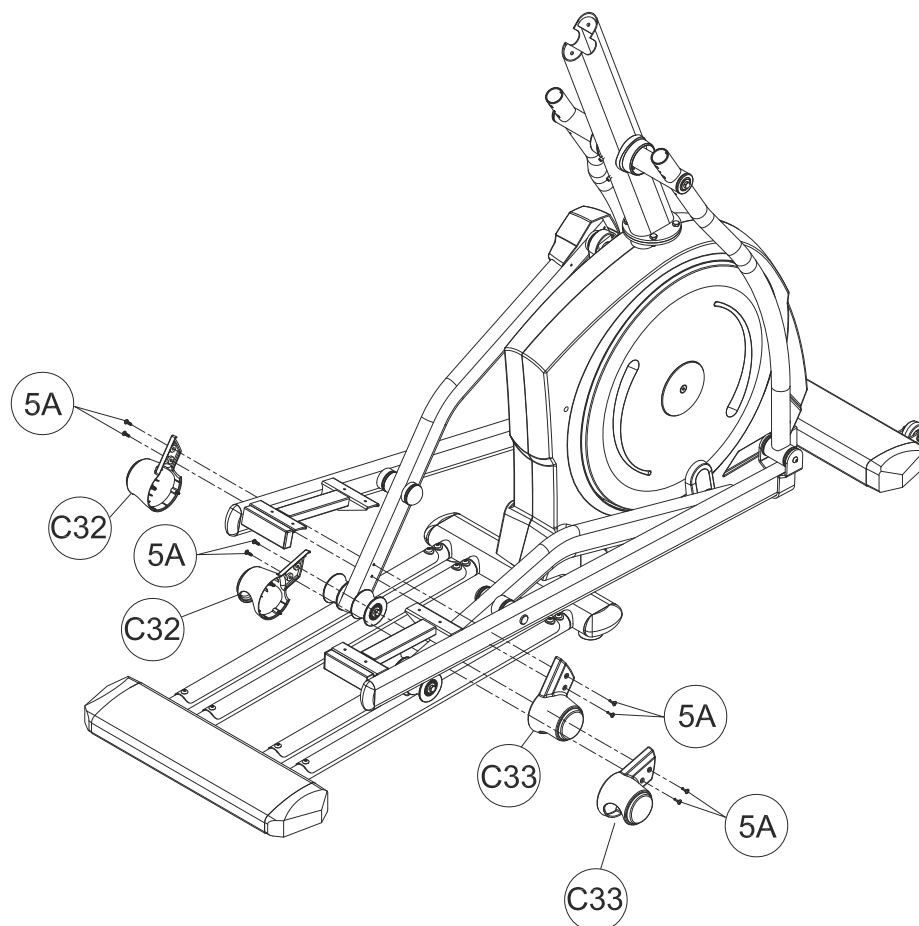
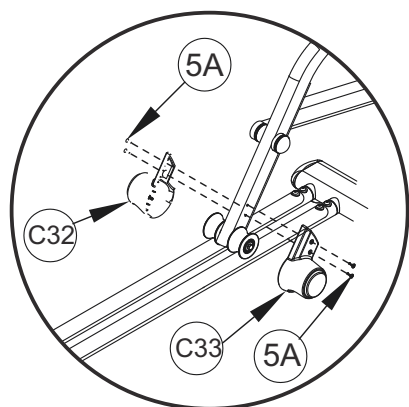

**Step 8: Assembling the Fixed Handlebars**

Pass the cable (D04) protruding from the top of the handlebar shaft (A02) and the cables from the handlebars (A15) through the opening of plate of the cockpit bracket on the handlebars.

Pull out the cable ends only as far as necessary to connect them to the cockpit. Then attach the fixed handle (A15) to the upper end of the handlebar shaft (A02) with two Allen screws M8x25 (7A).

**⚠ CAUTION:**

Make sure that the cables do not get pinched or damaged whilst assembling the handlebars.

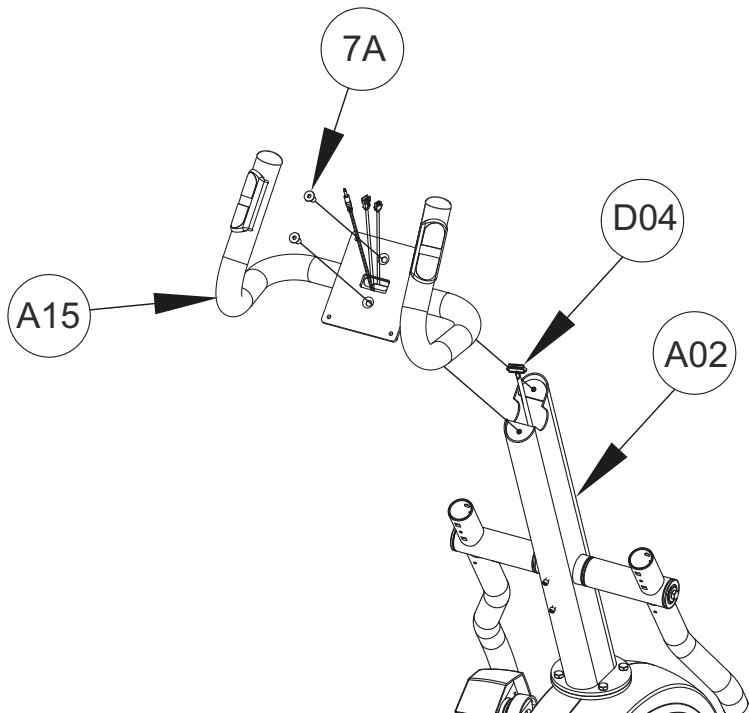

**Step 9: Assembling the Pendulum Handles**

Insert the left pendulum handle (A13) into the mount of the left pendulum tube (A03), then attach the pendulum handle (A14) to the right pendulum tube (A04). Both pendulum handles have been marked with a sticker and so are easy to identify. Now fix the pendulum handles using two carriage bolts M8x50 (1A), two curved washers M8 (4A) and two locknuts (3A).

Repeat with the right pendulum handle (A15).

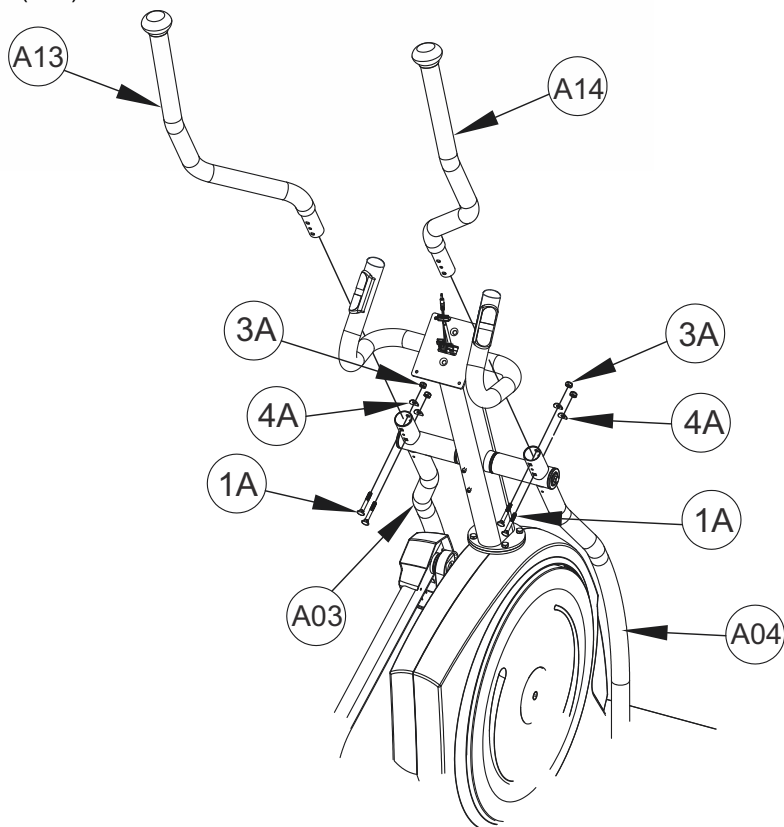

### Step 10: Assembling the Handlebar Stem Cover

Attach the two handlebar covers (C07-left / C08-right) at the joint between the handlebar stem (A02) and the base frame using two pan head screws M5x16 (5A).

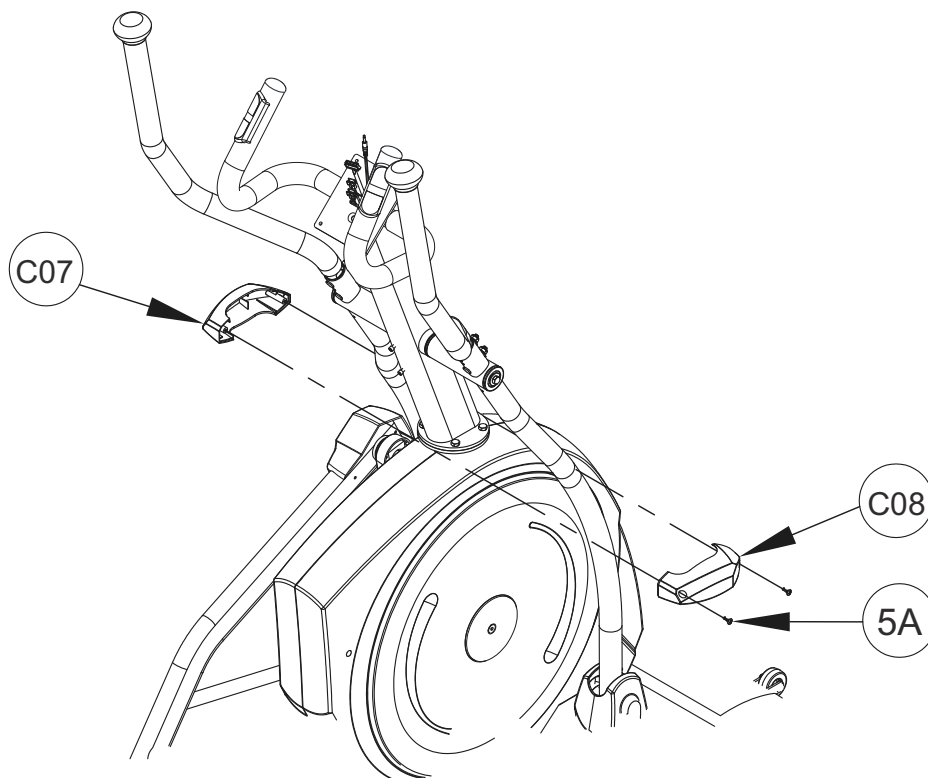

### Step 11: Assembling the Pendulum Tube Covers

Attach two pendulum tube covers (C17-left / C18-right) at the joint between the right pendulum handle (A14) to the right pendulum tube (A04). Use four pan head screws M5x16 (5A). Repeat the same procedure with the left pendulum handle (A13) and pendulum tube (A03).

ENG

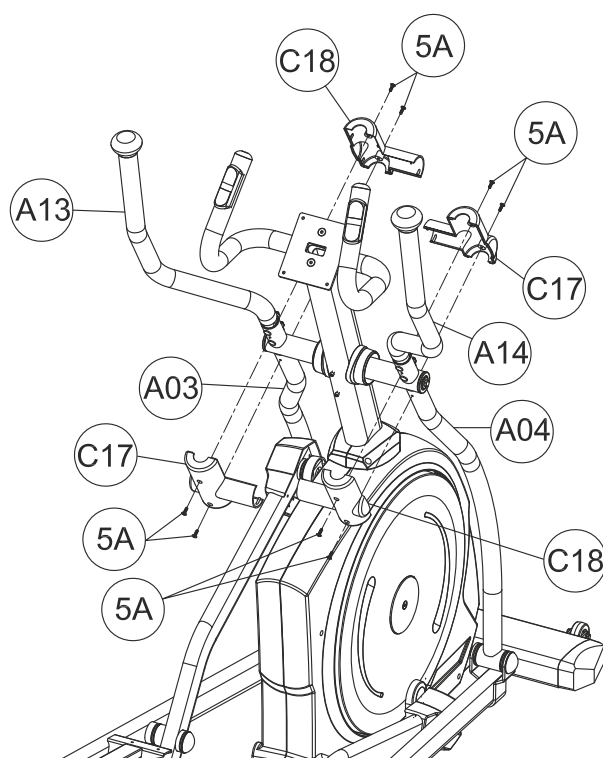
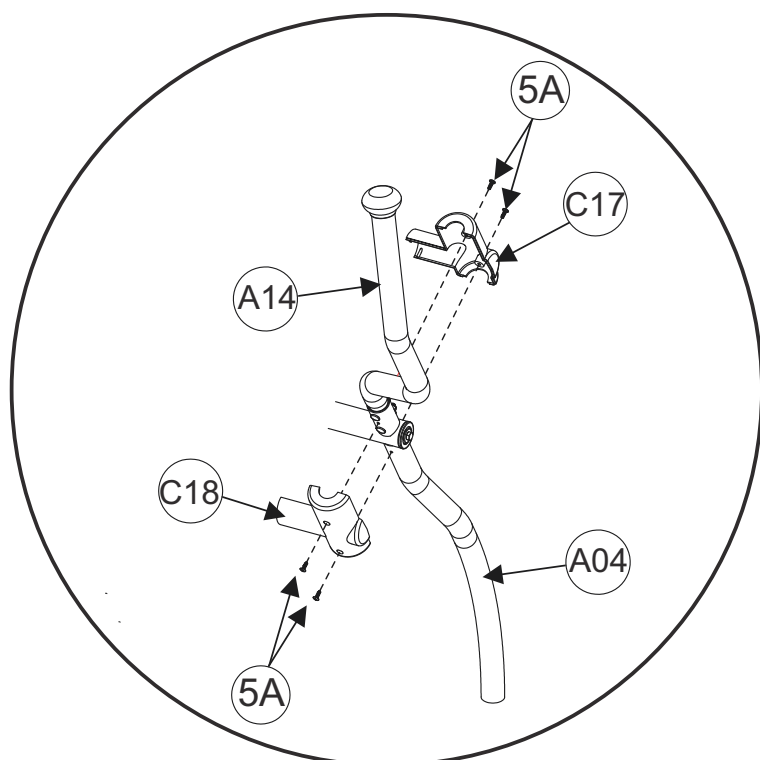

### Step 12: Assembling the Treads

Attach one of the two treads (C12) to the rear brackets on the left and right pedal tube (A05-left/A06-right). Fix each tread with four button head screws M6x15 (2A). Then press four cover plugs (C34) over the four screw holes on the top of the tread (C12).

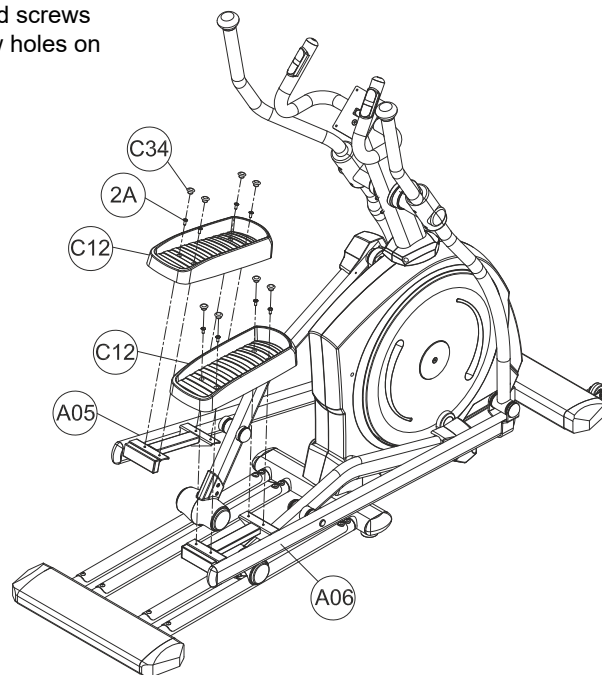

### Step 13: Assembling the Bottle Holder

Loosen and remove the two button head screws M5 (B15) from the handlebar stem (A02).

Attach the bottle holder (C27) to the handlebar stem (A02) with the same two round head bolts M5 (B15).

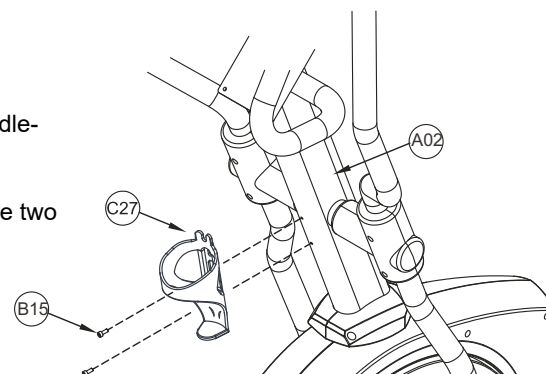

### Step 14: Assembling the Cockpit

- Pull the cables from the handlebar stem through the handlebar
- Connect the cables from the handlebar stem with the cockpit cables
- Push the rest of the cable back into the handlebar stem
- Fix the handlebars with a second person holding the cockpit close to the handlebars.

Loosen the four button head screws (B17) on the back of the cockpit (D02). Connect the cables that protrude from the cockpit (D02) with the cables that protrude from the fixed handle (A15).

Please note that the two hand pulse measurement cables have identical connections. The order of connection does not matter. The other cables can be clearly assigned on the basis of their connections. Secure the cockpit (D02) to the cockpit holder of the fixed handle (A15) with the four button head screws (B17).

**⚠ CAUTION:**

Make sure that you do not pinch or damage the cables.

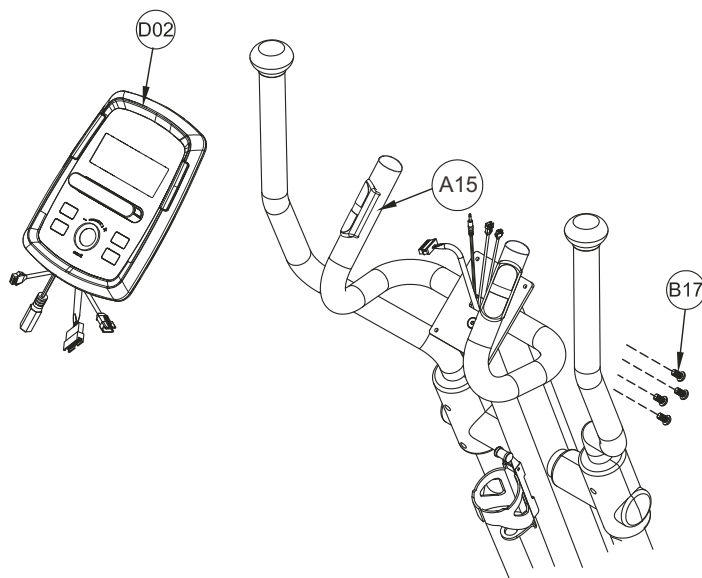

Make sure your exercise equipment is always level. In order to compensate for minor bumps or slopes in the floor, adjustable feet are fitted on the right and left of the front and rear stands and on the sliding frame. To make sure the position of the device is level, first turn all feet to the lowest position (position A). If necessary, adjust the feet until the device is level and stable.

If the adjustment range of the levelling feet is not enough to allow the training device to stand safely, please check the surface of the location and, if necessary, choose a different location, where a safe and level position can be ensured.

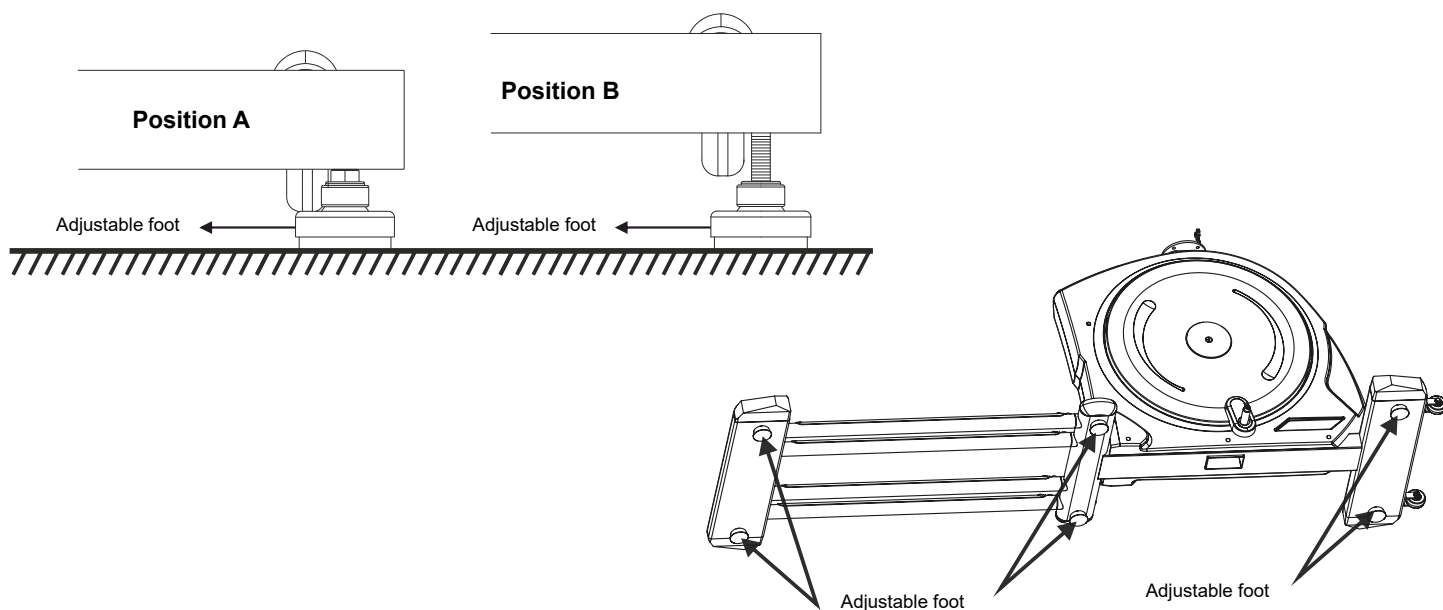

## Transport

In order to transport your training device simply and safely, the front standpipe is equipped with transport wheels.

To transport the exerciser, stand behind the rear end of the glide frame and grasp the rear cross tube with both hands. Lift the training device upwards until the weight rests on the transport rollers.

Now you can simply push the exercise machine on the transport rollers to the desired position.

When lifting, transporting and setting down always make sure that you have a firm, secure footing.

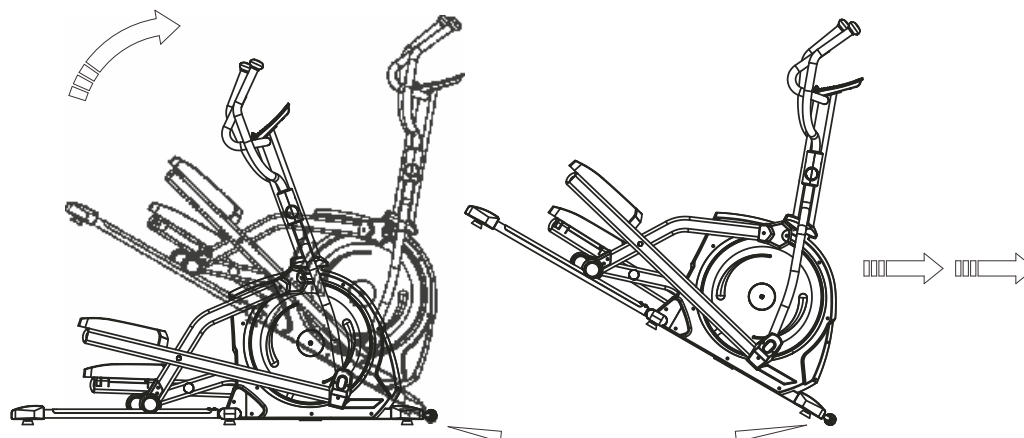

## Safety Distance

Choose training area which allows you free space on all sides and the greatest possible security.

The safety area should always be at least 100 cm to each side, and 100 cm behind and in front of the training device.

## Location & Storage

This training device is designed for use only in dry, well-ventilated indoor areas. Do not use or store it in damp or wet areas, such as saunas, swimming pools, etc. and in outdoor areas, such as balconies, terraces, gardens, garages, etc.

These locations may result in electronics defects, corrosion and rust due to the high humidity and low temperatures prevailing there. Warranty claims for damage of this kind will not be accepted.

Please choose a dry, level and well-ventilated training or storage area for your training equipment. For your own sake also make sure that the training site is sufficiently ventilated during exercise to allow optimal oxygenation.

Before you bring your training device back into operation after a long period of non-use, make sure beforehand that all fastening and parts are secure.

## Maintenance & Care

### CAUTION

Before starting cleaning, maintenance and / or repair work, the exerciser must be completely disconnected from the power supply. This will only be the case if the mains cable is disconnected from the power socket and from the training device. Therefore, first disconnect the electrical plug from the power socket, and then disconnect the mains cable from the exerciser. The mains cable may only be reconnected to the training device and the power supply when all work has been completed and the proper functional condition of the device has been restored.

### Cleaning

Clean your training device after each workout. Use a damp cloth and soap. Never use solvents. Regular cleaning contributes significantly to the preservation and longevity of your training device. Due to the chemical composition of body sweat, this is the main cause of corrosion (rust) if not removed immediately. Therefore, after every training session, check whether body perspiration and / or other fluids have got onto the device. If this is the case, the affected components / housing parts must be cleaned.

**Please note** that damages caused by body sweat or any other liquids are not in any way covered by the warranty.

During training, make sure that no fluid can enter the training device or the computer.

### Maintenance

#### Checking the fastenings

Check the tightness of nuts and bolts at least once a month and re-tighten if necessary.

#### Lubricating the sliding tubes

The top of the sliding tubes must be cleaned and lubricated regularly. Clean the sliding tubes with a damp cloth and some liquid hand soap or detergent. For professional cleaning we recommend the MAXXUS® Degreaser Spray. Then dry the sliding tubes thoroughly and lubricate the top of the tubes with liquid silicone or MAXXUS® lubricant spray to form a thin layer.

With frequent use, you should clean and lubricate the sliding tubes once a week. Lubricate the sliding tubes immediately if squeaking sounds occur during training. Care and cleaning agents are available in our online shop at [www.maxxus.com](http://www.maxxus.com) or in our showroom in Weiterstadt.

#### Lubricating the axles on the handlebar stem and on the drive discs

The two transverse axles on the handlebar stem, and the axles on the large drive discs, should be lubricated once every 6 months with multipurpose grease - please refer to the appropriate section in this manual.

**Mains Cable**

Insert the connector of the power cable supplied into the socket located on the front of the main housing. Then connect the mains cable to a power socket.

**⚠ WARNING**

This device is only to be connected to an earthed socket installed by a qualified electrician. Do not use a socket strip. If an extension cable is required, then it must comply with DIN standards, VDE regulations and guidelines, technical rules issued by other European Union member states or other states which are party to the Agreement on the European Economic Area.

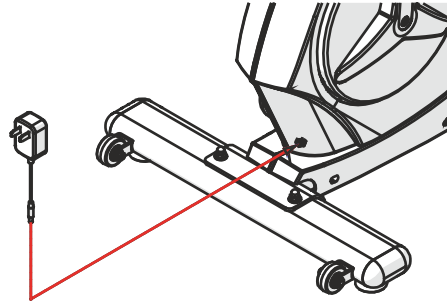
**Connecting the device****⚠ WARNING :**

Before connecting the mains adapter to the device, always check that it is the mains adapter supplied with the device. Using a different mains adapter may damage the electronic components of the device, for which the manufacturer assumes no liability.

Always connect the power cable to the exerciser before connecting it to a power outlet. If you want to disconnect your exerciser from the power supply, always disconnect the power cable from the mains first.

**Switching on the device**

First connect the power cable to the exerciser and then connect the mains cable to the power socket, the cockpit turns on automatically. If the training device is already connected to the mains, but the cockpit is in stand-by mode, activate the cockpit by pressing any key or by moving the pedals.

**Turning off the device**

When inactive for more than 4 minutes, the cockpit automatically switches to stand-by mode. Once you have finished your workout you should always disconnect the exerciser from the mains. Always unplug the mains cable from the wall socket first and then remove the power cable.

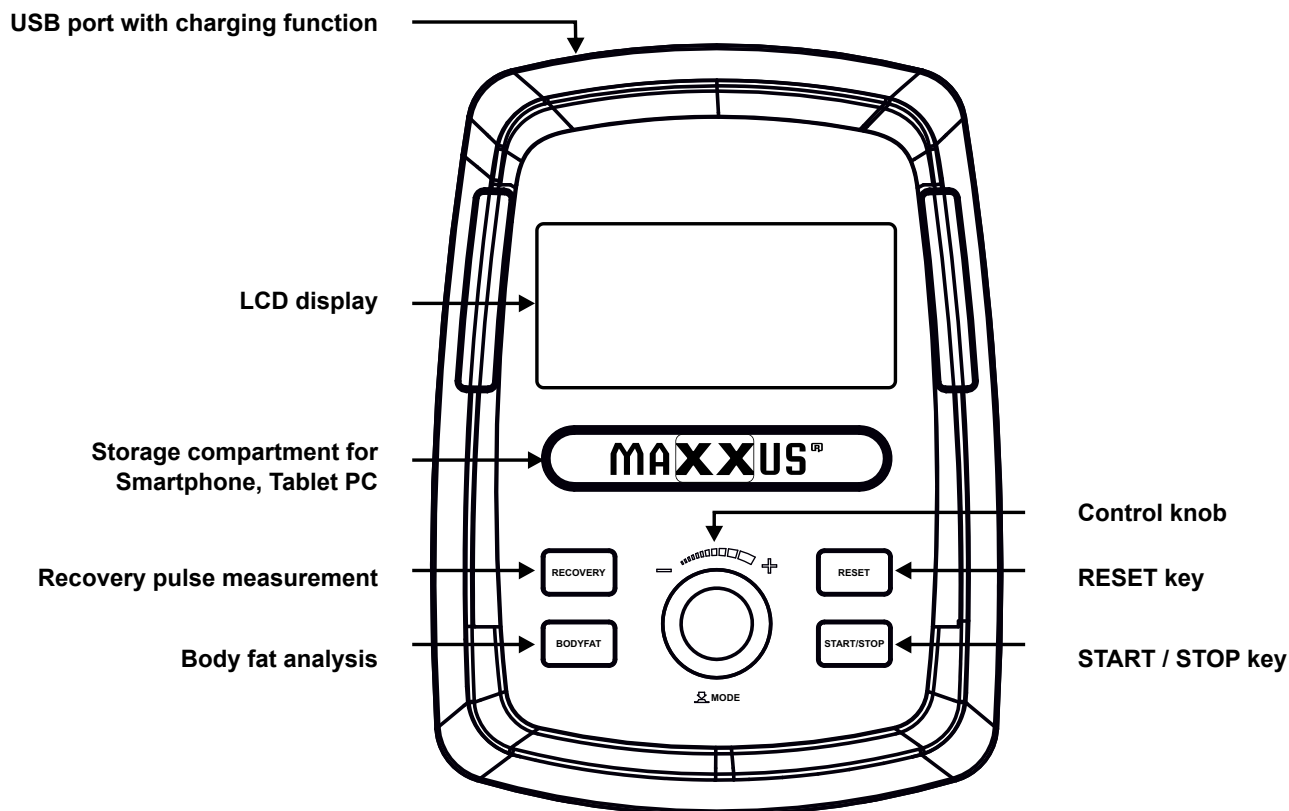

The cockpit constantly shows the current training values.

## TIME

Specification of the training time. For a given training session, the computer counts down the time to "00:00." The training time can be set from "01:00" to "99:00" minutes in one-minute increments. If no time is specified, the computer will count the training time from „00:00" up to a maximum of „99:00" minutes.

## DISTANCE

Specification of the training distance in kilometres. For a given training session, the computer counts down the distance back to "0.00." The training distance can be set from 1.0 to 99.0 Kilometres in 1.0 km increments to maximum of 99.0 kilometres. If no training distance is specified, the computer will count the kilometres from 0.0 to a maximum of 99.0 kilometres.

## CALORIES\*

Indication of energy consumption in Kcal. For a given calorie consumption, the computer counts the calories down to 0. The calorie consumption can be set from 10 to 990 K in 10-Kcalorie increments. If the calorie consumption is not specified, the computer counts the K-calories from 0 to a maximum of 990 K-calories

## Pulse or heart rate display - PULSE

When using the hand pulse sensors displays the current pulse value in beats per minute. When using an optional transmitter chest belt (not included) displays the current heart rate in beats / minute.

## SPEED

Current speed in km / h. Value is displayed alternately with RPM in the same window.

## Revolutions per minute - RPM

Specification of the current wheel revolution per minute (RPM). Value is displayed alternately with SPEED in the same window.

## Resistance - LEVEL

Display of the currently selected resistance level from 1 to 16.

## Power - WATT\*\*

Display of the power output in Watts.

### \* Warning about the calorie measurement

Energy consumption is calculated by means of a general formula. It is not possible to determine the exact energy consumption individually as this requires a large amount of personal data. The energy consumption displayed is approximate and not an exact value.

### \*\*Warning about the Watt display

Since this is a training device suitable for non-therapeutic purposes, the displayed value in Watts is not a calibrated value. The displayed power generated may differ from the actual power generated.



## Keypad

### START/STOP Key

START Function:     – Start the selected training program or training profile  
                           – Activate the QUICK START function

PAUSE Function:     If the START / STOP key is pressed during training, the display of training values stops, and the pause mode is activated. This allows an interruption of training.  
                           To end the pause, press the START / STOP key again.

### RESET Key

If the key is pressed constantly for more than 5 seconds, all values are automatically reset to zero.

To change the user, exit the current program by pressing the START / STOP key. Then press the RESET until the display switches on again.

### Control Knob

Turning Function:    – Specification of training values  
                           – Input of date (eg age)  
                           – Regulating the resistance level

Pressing Function:   – Confirmation of inputs

### RECOVERY

Key to start the recovery pulse measurement.

### Body Fat Measurement - FAT

Key to start the body fat measurement.

## User Settings

After the cockpit has been switched on, the display shows "U1". There are four user profiles available U1 ~ U4. These are fixed, i.e. the user data is stored permanently.

### Selecting a User Profile

Turn the control knob to select the desired user profile and confirm your selection by pressing it.

ENG

### Gender Input

Turn the control knob to select your gender and confirm your selection by pressing it.

### Age Input

Enter your age by turning the control knob and confirm your entry by pressing it.

### Height Input

Enter your height by turning the control knob and confirm your entry by pressing it.

### Weight Input

Enter your body weight by turning the control knob and confirm your entry by pressing it. After you have confirmed the input of body weight the display automatically changes to the training menu.

If you have already created a user profile, select this as soon as you have switched on the cockpit by turning the control knob. Then the information for gender, age, height and body weight will be checked. If the details are still correct, confirm them by pressing the control knob. If some inputs have changed, correct them accordingly and confirm by pressing the control knob

## Quick-Start

Turn on the training device and press the START / STOP key. The training time will start to run, and you can start training. At any time during training, you can adjust the resistance level from 1 to 16 by turning the control knob clockwise / anti-clockwise. Since no target value can be specified in this type of training, you must end the training yourself.

## Manual Training - MANUAL

### Step 1: Program Selection

Turn on the exerciser. An "M" will flash in the upper part of the display. If a different symbol is flashing, select "M" by turning the control knob clockwise / anti-clockwise. Confirm your selection by pressing the control knob.

### Step 2: Program Selection Resistance Level

The value in the "LEVEL" window will flash. Set the desired resistance level from 1 to 16 by turning the control knob clockwise / anti-clockwise. This can be changed individually during training at any time. Confirm your selection by pressing the control knob.

### Step 3: Specification of the Target Values

You now have the choice of three different goals:

#### Training Time ("TIME"):

The value in the "TIME" window flashes. If you want to specify the training time, enter it by turning the control knob clockwise / anti-clockwise. You can set the exercise time from 1:00 to 99:00 minutes in 1-minute increments. Confirm your selection by pressing the control knob.

If you do not want to specify the training time, press the control knob directly to confirm. The value in the "TIME" window should show "00:00".

#### Training Distance ("DISTANCE"):

The value in the "DISTANCE" window flashes. If you want to specify the training distance, enter it by turning the control knob clockwise / anticlockwise. You can set the training distance from 1.0 to 99.0 kilometres in 1-kilometre increments. Confirm your selection by pressing the control knob. If you do not want to specify the training distance, press the control knob directly to confirm. The value in the "DISTANCE" window should show "0.00".

#### Calorie Consumption ("CALORIES"):

The value in the "CALORIES" window flashes. If you want to specify the calorie consumption, enter it by turning the control knob clockwise / anticlockwise. You can set calorie consumption from 10 to 990 K-calories in 10 K-calorie increments. Confirm your selection by pressing the control knob.

If you do not want to specify the calorie consumption, press the control knob directly to confirm. The value in the "CALORIES" window should show "0".

#### Note:

It does not make sense to specify more than one training goal per training session. If you do, training will stop after reaching the first target value.

### Step 4: Specifying the Pulse Upper Limit

The value in the "PULSE" window flashes. You can now set a pulse upper limit of 30 to 230 heartbeats / minute by turning the control knob clockwise / anticlockwise. If your actual heart rate reaches this level during exercise, a warning will sound. If you do not want to set a pulse upper limit, press the control knob directly to confirm. The value in the PULSE "window should show " 0 ".

### Step 5: Training Start

Press the START / STOP key to start exercising.

### End Training

After the predetermined training goal has been reached, training will end automatically

### Controlling the Resistance Level

During exercise, you can change the currently selected brake level at any time by turning the control knob clockwise / anticlockwise.

## Training Profiles P1 – P12

In this type of training, the user can choose from twelve pre-programmed training profiles. The profile is not changeable; however, the user has the option of adjusting the intensity of the respective profile according to their current state of fitness.

### Step 1: Program Selection

Turn on the exerciser. The upper part of the display flashes "M". Select the desired training profile by turning the control knob clockwise / anti-clockwise.

### Step 2: Setting the Training Level

Select the desired training level by turning the control knob clockwise / anti-clockwise. Confirm your selection by pressing the control knob.

### Step 3: Setting the Training Time

The value in the "TIME" window flashes. Enter the training time by turning the control knob clockwise / anticlockwise. You can set the exercise time from 1:00 to 99:00 minutes in 1-minute increments.

### Step 4: Training Start

Press the START / STOP key to start exercising.

### Training End

When the desired training time has been reached, training will end automatically.

### Setting the Training Level

During training, you can change the currently selected training level within the given frame by turning control knob clockwise / anti-clockwise at any time.

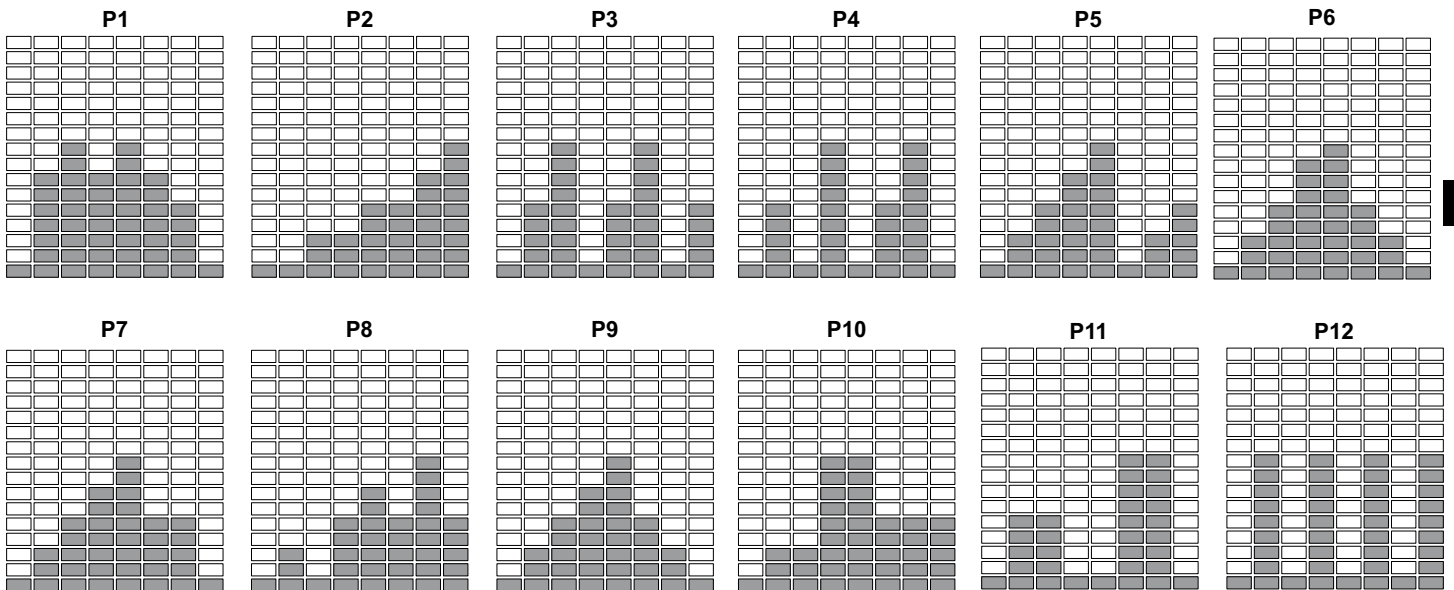

ENG

## Free Training Profile (USER)

Here you can create a training profile per user profile yourself and save it permanently.

### Step 1: Selecting a Program

Turn on the exerciser. The upper part of the display flashes "M". Select the program "U" by turning the control knob clockwise / anti-clockwise and confirm your selection by pressing it.

### Step 2: Programming the Training Segments

The first of a total of eight training segments will flash in the display. Set the desired resistance level from 1 – 16 for the first training segment by turning control knob clockwise / anti-clockwise and confirm your entry by pressing it. Now the second segment flashes. Repeat this procedure with this segment and all the way through to segment 8. After you have confirmed the input for the 8th segment by pressing the control knob, this training profile will be permanently stored.

### Step 3: Setting the Training Time

When the first segment flashes again. Press the control knob until the value in the "TIME" window flashes. Then enter the exercise time by turning the control knob clockwise / anti-clockwise. You can set the exercise time from 1:00 to 99:00 minutes in 1-minute increments.

### Step 4: Training Start

Press the START / STOP key to start exercising.

### Training End

After the training time has expired, the training will end automatically.

### NOTE:

If you want to change the saved training program, switch on the cockpit. Select the program "U" by turning the dial clockwise / anti-clockwise and confirm your selection by pressing it. Now the first segment flashes again. Press the control knob until the value in the "TIME" window flashes. Enter the exercise time by turning the dial clockwise / anti-clockwise.

You can set the exercise time from 1:00 to 99:00 minutes in 1-minute increments. Now press the START / STOP key to start training.

## Heart Rate Controlled Programs (HRC)

These programs are heart-rate-controlled exercise programs. The user specifies a desired target heart rate. This is permanently compared by the cockpit with the actual heart rate of the user. If the actual heart rate is lower than the desired target heart rate, the cockpit automatically increases the resistance. If the value is higher, the cockpit automatically reduces the resistance.

The main requirement for these programs is a permanent and accurate transmission of heart rate values. For this reason, these programs can only be used together with an uncoded heart rate chest belt which is available as an extra accessory. It is not possible to use these programs with hand-pulse sensors. Please also read the chapter "Heart rate measurement" in this manual.

### Step 1: Selecting a Program

Turn on the exerciser. The upper part of the display flashes "M". Select the heart symbol by turning the control knob clockwise / anti-clockwise and confirm your selection by pressing it.

### Step 2: Age Input

The display will show the letter "A" and the value "25" will flash, enter your age from 1 to 99 years by turning the control knob clockwise / anticlockwise, and confirm your entry by pressing it.

### Step 3: Selecting the HRC Mode

By pressing the UP & DOWN keys, you can now choose between the following HRC modes:

**50%** – Training with a target heart rate of 50% of the maximum heart rate

**75%** – Training with a target heart rate of 75% of the maximum heart rate

**90%** – Training with a target heart rate of 90% of the maximum heart rate

**TA** – Training with an individual target heart rate

Please also read the section "Warning for Pulse & Heart Rate Measurement" in this manual.

Select the desired modes by turning the control knob clockwise / anti-clockwise.

If you select 55%, 75% or 90%, the corresponding target heart rate will be displayed directly. Confirm your selection by pressing the control knob.

To train with an individual target heart rate, select the TA mode by turning the control knob clockwise / anti-clockwise and confirm the selection by pressing it. The "PULSE" window will flash "100." Now enter the desired target heart rate between 30 and 230 heartbeats / minute again by turning the control knob clockwise / anticlockwise and confirm your entry by pressing it.

**Step 4: Setting the Training Time**

The value in the "TIME" window flashes. Enter the training time by turning the control knob clockwise / anti-clockwise. You can set the exercise time from 1:00 to 99:00 minutes in 1-minute increments.

**Step 5: Training Start**

Press the START / STOP key to start exercising.

**Training End**

After the training time has expired, the training is automatically ended.

**Program Procedure**

The cockpit determines the current heart rate of the user and compares it continually with the desired target heart rate. If the current heart rate is lower or higher than the target heart rate, the cockpit automatically increases or decreases the resistance level.

If the current heart rate is within +/- 5 beats / minute below or above the target heart rate, the cockpit will maintain the current resistance level.

If the cockpit cannot determine the user's heart rate, the display shows "?". In this case, check the correct position and battery power of the chest belt and make sure that it is an uncoded belt with the 5 kHz transmission frequency.

**Example:**

Target heart rate is 120 - no change in the brake level at a current heart rate of 115 ~ 125 beats / minute.

**Watt-controlled training programs (WATT)**

In this type of training the power in watts selected by the user is kept constant permanently by the cockpit. The user's output (watts) results from the current resistance level and the current pedalling speed. To keep the power constant, the cockpit reduces the resistance level as soon as the user increases the pedalling speed. If the user reduces the pedalling speed, the cockpit automatically increases the resistance level. This is also called speed-independent training

The user has three fixed watt-training profiles and a watt-constant program to choose from.

**Step 1: Selecting a Program**

Turn on the exerciser. An "M" will flash in the upper part of the display. Select the program "W" by turning the control knob clockwise / anticlockwise and confirm your selection by pressing it.

**Step 2: Setting Watt Value**

The value in the "WATT" window flashes. Enter the desired wattage by turning the dial clockwise / anti-clockwise. Inputs from 10 to 350 watts in 5-watt increments are possible. Confirm your entry by pressing the control knob.

**Step 3: Setting the Training Time**

The value in the "TIME" window flashes. Enter the desired training time by turning the control knob clockwise / anti-clockwise and confirm your entry by pressing it.

**Step 4: Training Start**

Press the START / STOP key to start exercising.

**Training End**

After the training time has expired, training will end automatically.

## Recovery Heart Rate (RECOVERY)

The recovery test measures how quickly you recover, i.e. how quickly and by how much your heart rate decreases after training.

After completing a workout, or after stopping the workout by pressing the Stop key, press the RECOVERY key and immediately place your hands on the hand pulse sensors. If you are wearing a chest strap, you do not need to hold on to the hand pulse sensors. Now the cockpit will try to determine your pulse for 10 seconds. If this fails, the test is automatically terminated.

If the cockpit has detected your pulse, a countdown of 60 seconds starts in which you must keep hold of the hand pulse sensors all the time (this is also not necessary if you are wearing a chest strap).

After the 60 seconds have elapsed, you can read the result on the display and compare it with the following table.

Result	Evaluation
F1	Excellent
F2	Very good
F3	Good
F4	Satisfactory
F5	Sufficient
F5	Poor

## Body Fat Analysis (Body Fat)

This program determines the percentage of body fat and the BMI of the user.

Press the FAT key. The currently selected user profile is displayed as "U1". If the wrong user profile has been selected, press the RESET key and select the correct user profile. Then press the FAT key again and grasp the hand pulse sensors with your hands. After successful measurement, the percentage of body fat is displayed with the corresponding symbol and BMI.

Age	BMI
19 - 24 years	19 - 24
25 - 34 years	20 - 25
35 - 44 years	21 - 26
45 - 54 years	22 - 27
55 - 64 years	23 - 28
> 64 years	24 - 29

### Body-Mass-Index (BMI)

This value is calculated from the ratio of body weight to height and is used to assess the body weight of a person in relation to their height. Please note that the BMI is only a rough guideline, as it does not account for physique and gender or the individual composition of the body mass of fat and muscle tissue. The "ideal" BMI depends on the age.

BMI

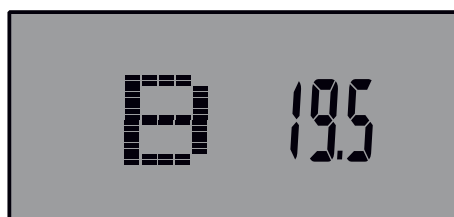

Body fat percentage %

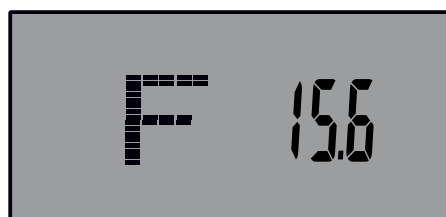

Symbols representing the body fat percentage

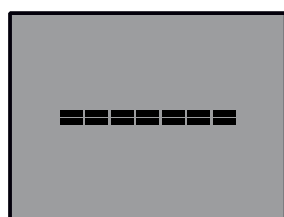

Low

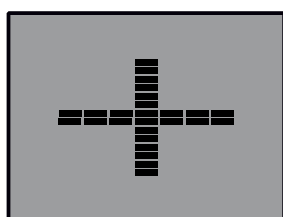

Normal



Raised

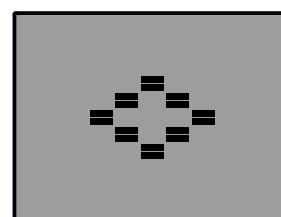

High

### USB Charging Function

The cockpit has a USB connection located at the top of the cockpit. This connection is to be used only for charging of smartphones or tablet-PC's during training. The cable required for this is not included in delivery.



## Bluetooth Receiver and APP Usage

The cockpit of your training device comes ready fitted with an integrated Bluetooth receiver. This Bluetooth receiver allows the fitness device to be controlled from your smartphone or table PC via an App.

Connect the iC+ Training-App with your training device as follows:

### Step 1

Download the iC+ Training-App from the appropriate Store onto your smartphone or tablet PC.



For requirements of compatible devices and required software versions, please refer to the appropriate store page.

\* **Note:** If the links are no longer valid, please enter "iC + Training" or "iConsole +" in the search bar of the relevant store.

The logo to search for for the "iConsole+" APP has orange writing on a white background.



### Step 2

Activate the Bluetooth function on your smartphone or tablet PC  
Open the iC+ Training App

### Step 3

Select "GET STARTED" in the top right of the menu. Then select the required training type, such as "QUICK START"

### Step 4

A list of available Bluetooth devices will appear on the display of your smartphone or tablet PC. Make sure your training device is switched on. Select your training device from the list. The name of the training device starts with "FAL ..." or "MAXXUS". After successful connection, a tick symbol will appear. Your training device will now be stored by the iC + Training App so you can start training straight away the next time you want to train.

### Step 5

After successfully pairing the App with your training device, you can continue training by clicking on the arrow in the top right corner of the display.

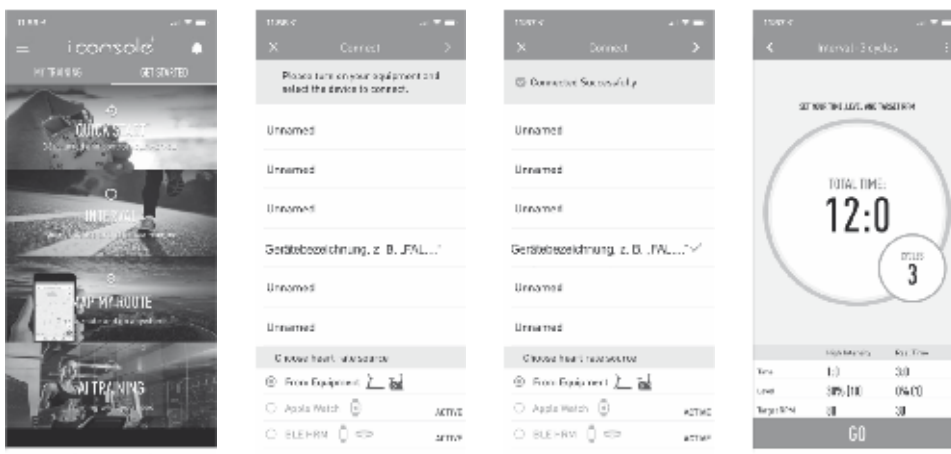

Please note that the MAXXUS Group GmbH & Co. KG is not the manufacturer of the iC + Training App and therefore are not responsible for their content or features.

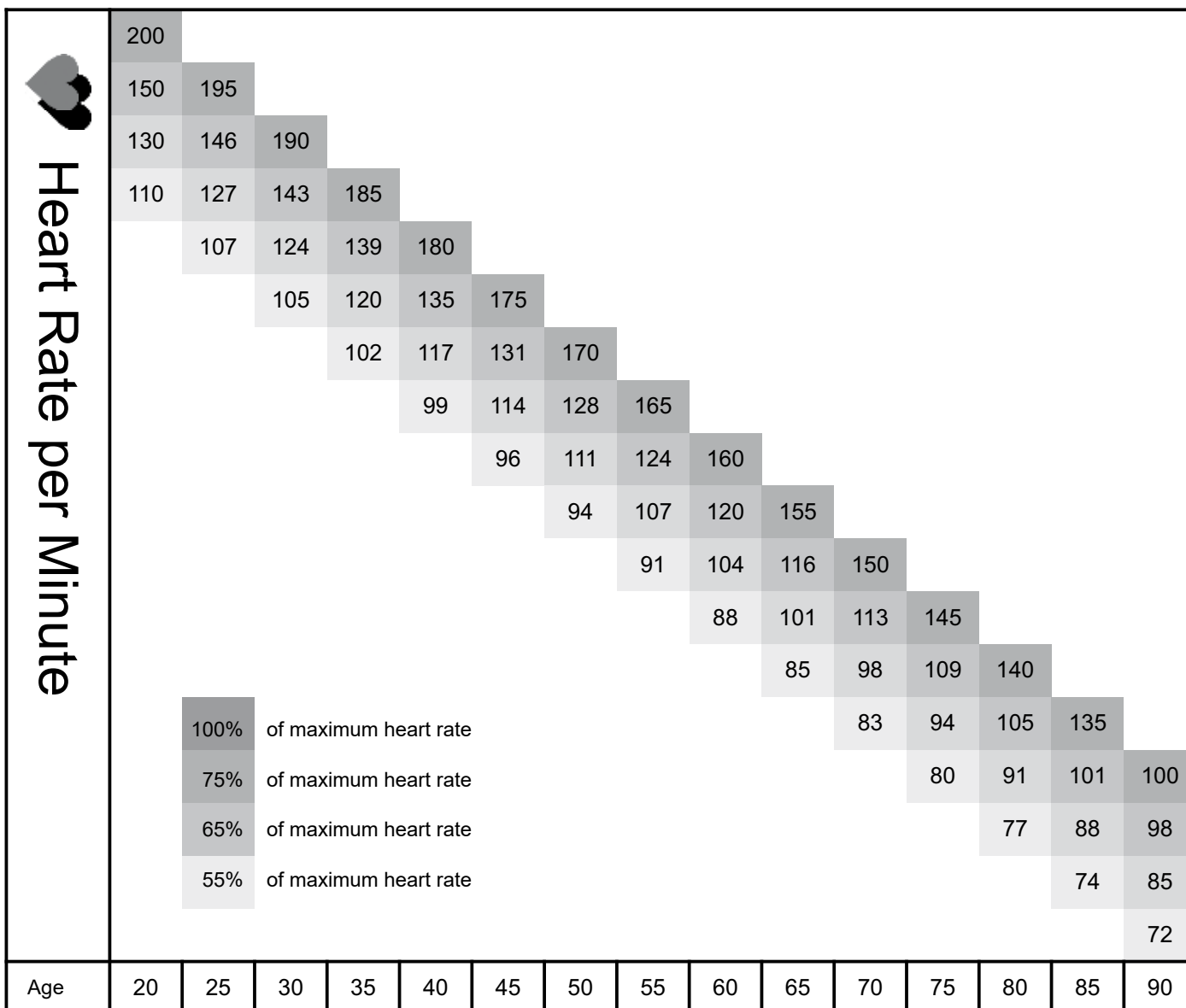

**Calculating your personal heart rate when training**

Calculate your personal heart rate when training as follows:

**220 - Age = maximum heart rate**

This value represents your maximum heart rate and serves as a basis from which to calculate your personal training heart rate. Set the calculated heart rate at 100%

**Wellness and Health - target zones = 50 to 60% of the maximum heart rate.**

This training zone is ideally suitable for people who are over-weight and/or older beginners, or people starting again after a longer break from training. Training in this zone the body will burn approx. 4-6 calories per minute to produce energy. The percentage ratio per calorie is approx. 70% fat, 25% carbohydrate, and 5% protein.

**Fat burning - target zone = 60 to 70% of the maximum heart rate**

This training zone is suitable for athletes and sports people who aim to lose weight. Training in this zone the body will burn approx. 6-10 calories per minute to produce energy. The percentage rate per calorie is approx. 85% fat, 10% carbohydrate, and 5% protein.

**Condition & Fitness - target zone = 70 to 80% of maximum heart rate**

This training zone is ideally suitable for athletes and sports people who aim to improve their stamina and/or condition. Training in this zone the body will burn approx. 10-12 calories per minute to produce energy. The percentage rate per calorie is approx. 35% fat, 60% carbohydrate, and 5% protein.

For optimum effects in training results you should calculate the average value of the selected target zone (also see above table):

Wellness & Health - target zone average value = 55% of maximum heart rate

Fat burning - target zone average value = 65% of maximum heart rate

Kondition & Fitness - target zone average value = 75% of maximum heart rate



## **Warning about Pulse and Heart Rate Monitoring**

**CAUTION:** Pulse and heart rate monitoring systems may be inaccurate. Excessive training can cause serious injury or even death. If you feel unwell and / or faint, stop training immediately. Make sure all users of your exercise device are familiar with this information, understand it and apply it unconditionally.

### **Pulse Rate Monitoring using Hand Sensors**

Most exercise equipment is equipped with hand pulse sensors. These are mostly in the cockpit or integrated into the handrails. These hand sensors are used for short-term determination of the pulse rate. To do this, you need to cover the sensors with both hands at the same time. After a short while, the display shows the current pulse rate. This measuring system is based changes in electrical skin resistance measured by the hand sensors due to the heartbeat which causes blood pressure fluctuations. These changes are summarized to a mean value and shown in the display as the current pulse rate.

#### **CAUTION.**

For large parts of the population, the pulse-induced skin resistance change is so minimal that usable values cannot be derived from the measurement results. Also callouses on the palms, damp hands and body shakes, which in many forms of exercise inevitable, prevents correct measurement. In such cases, the pulse value is displayed incorrectly or not at all.

Please check in the case of a faulty or failed measurement, whether this occurs only with one or with several people. If the display of the pulse does not work only in individual cases, the device is not defective. In this case we recommend the use of a chest belt to achieve a permanently correct pulse display. This is available as an accessory

### **Heart Rate Measurement using a Chest Belt**

Many MAXXUS® training devices are already fitted with a receiver as standard.

Using a chest belt (we recommend the exclusive use of an uncoded POLAR® chest strap) allows you to wirelessly measure heart rate. The chest belt is as accessories available.

This optimal, ECG-accurate type of measurement takes the heart rate by means of a transmitter chest belt directly from the skin.

The chest belt then sends the pulse via an electromagnetic field to the built-in cockpit receiver. We recommend you always use of a chest belt for heart rate measurement during heart rate-controlled programs.

#### **CAUTION**

The determination of the current heart rate by means of the chest belt serves only to display the current heart rate during exercise. This value says nothing about the safety and effectiveness of the training. Also, this type of measurement is in no way designed or suitable for medical diagnostic purposes.

Therefore, discuss with your family doctor the most suitable procedure for you and create your exercise plan before you start exercising.

This applies especially to those who:

- have not been physically active for a long period of time
- are overweight
- are older than 35 years
- have too high or too low blood pressure
- have heart problems

If you are wearing a pacemaker or similar device, discuss this with your medical specialist before using a heart rate chest belt.

### Preparation Before Training

Before you start training make sure that not only your training device is in perfect condition, your body must also be prepared for training. Therefore, if you have not done any endurance training for some time, you should consult your GP and undergo a fitness check-up. Also discuss your training target; they will certainly be able to give you valuable advice and information. This applies to people who are over 35, have problems with overweight, heart or circulatory system problems.

### Training Plan

Essential to effective, target orientated, and motivating training is to have a forward-looking trainings plan. Plan your fitness training as an integral part of your daily routine. If you don't have a fixed plan, training can easily interfere with regular commitments or continually be put off to another unspecified time.

If possible, create a long term monthly plan and not just from day to day or week to week. A training plan should also include sufficient motivation and distraction during training sessions. An ideal distraction is to watch TV during training as this diverts your attention both visually and acoustically. Make sure that you reward yourself and set realistic targets such as to losing 1 or 2kgs in four weeks or to increase your training time by 10 minutes within two weeks for example. If you reach your targets, then reward yourself with a favourite meal which you have not allowed yourself till then.

### Warm-Up Before Training

Warm-up on your training device for 3-5 minutes at minimum resistance. This will best prepare your body for the up-coming exertion in training.

### Cool-Down After Training

Do not just get off your training device immediately the training session is finished. Like with the warm-up stage you should continue for 3-5 minutes at minimum resistance to cool down. After training you should stretch your muscles thoroughly.



#### Front Thigh Muscles

Support yourself with your right hand against the wall or on your training device. Bend your knee and raise your left foot backwards so you can hold it with your left hand. Your knee should be pointing straight down to the floor. Pull your leg backwards until you feel a light pulling in your thigh muscles. Hold this position for 10 to 15 seconds. Let your foot go and stand it back on the floor. Repeat the exercise with your right leg.



#### Inner Thigh Muscles

Sit on the floor. Pull the soles of your feet together in front of you raising your knees slightly. Grasp the upper sides of your feet and place your elbows on your thighs. Press your thighs down towards the floor with your arms until you feel a light pulling in your thigh muscles. Hold this position for 10 to 15 seconds. Make sure to keep your upper body straight throughout the exercise. Release the pressure from your thighs and slowly stretch out your legs to the front. Stand up slowly steadily.



#### Legs, Calves and Buttocks

Sit on the floor. Stretch out your right leg and bend your left leg to place the sole of your foot on your right thigh. Bend your top body over so you can stretch out your right hand to touch your right toes. Hold this position for 10 to 15 seconds. Let go of your toes and sit slowly and steadily up straight again. Repeat this exercise with your left leg.



#### Leg and Lower Back Muscles

Sit on the floor with your legs stretched out. Stretch forward with your hands and try to grasp the tips of your toes with both hands. Hold this position for 10 to 15 seconds. Let go of your toes and slowly and steadily sit back up straight again.

**Hydration**

Adequate hydration is essential before and during exercise. During a training session of 30 minutes it is possible to lose up to 1 litre of liquid. To compensate for this fluid loss apple spritzer mixed in the ratio of one-third apple juice to two-thirds mineral water is ideal since it contains electrolytes and minerals to replace those that the body loses through sweat. You should drink about 330 ml 30 minutes before the beginning of your training session. Take care to maintain balanced hydration during the workout.

**Training Frequency**

Experts recommend that you do endurance training 3-4 days a week to keep the cardiovascular system fit. Of course, the more you train, the faster you will achieve your set training goal. Note however, that you should plan sufficient training breaks during your workout plan, to give your body enough time for rest and regeneration. After each training session you should take at least one day off. Also for that fitness and endurance training: Less is more!

**Exercise Intensity**

In addition to the mistake of exercising too often, mistakes are made in the intensity of the training. If your training goal is to train for a triathlon or marathon, your training intensity will certainly be high. But since most people have training goals such as weight reduction, cardiac / exercise training, improvement of physical condition, stress reduction, etc. to strive for, training intensity to meet these goals should be adjusted. It makes most sense to work with the appropriate heart rate for the respective training goal. The information on the heart rate and the corresponding table in this manual will help you further.

**Duration of the individual training session**

For optimal endurance or weight reduction training, the duration of the individual training session should be between 25 and 60 minutes. Beginners and returnees should start with a low training period of 10 minutes or less in the first week and then slowly increase week by week.

**Training Documentation**

In order to design and evaluate your training effectively, you should prepare yourself a training plan in written form or as a computer table before starting your training

Here you should document training session. Data, such as distance, training time, brake force setting and pulse values should be recorded as well as personal data, e.g. body weight, blood pressure, resting heart rate (measured morning immediately after waking up) and personal well-being during exercise.

Enclosed you will find a recommendation for a weekly plan.

ENG

Calendar Week: ____ Year: 20 ____						
Date	Day	Exercise duration	Exercise distance	Calorie consumption	Ø Heart rate	Comments
	Monday					
	Tuesday					
	Wednesday					
	Thursday					
	Friday					
	Saturday					
	Sunday					
Week Result:						

## Technical Details

### Cockpit

Display of:

- Time
- Distance
- Calorie Consumption
- Power – WATT
- Resistance – Level
- Speed
- Wheel revolutions per Minute – RPM
- Pulse Rate (when using the hand sensors)
- Heart Rate (when using an optional chest belt)

### Technical details:

Brake system:	Motorized permanent magnet brake system
Resistance level adjustment:	Computer controlled
Resistance Levels:	1 - 16
Flywheel Weight:	Approx 9 kg
Drive System:	2-stage ribbed belt
Dimensions:	Approx. 192 x 68 x 170 (LxWxH)
Overall Weight:	Approx 93 kg
Maximum user weight:	160kg
Power supply:	220-230V - 50Hz
Mains adapter:	9V / 1.000mA

**Application:** Home Use

## Disposal



### European Disposal Regulations 2012/19/EU

Do not dispose your training device in the normal household rubbish.

Dispose the device at a communal waste disposal facility or at a registered waste disposal company.

Observe current regulations which apply accordingly. If in doubt seek advice from your local government office or county council as to where you can dispose of the device properly and in an environmentally sound manner.

### Batteries / Rechargeable Batteries (if applicable to your device)

Batteries and rechargeable batteries should never be disposed of in the household rubbish.

Please be aware that all batteries can contain toxic substances and all consumers are obliged by law to dispose these at an appropriate collection point either at your local government office, county council or retail outlet.

If in doubt seek advice from your local government office or county council as to where you can dispose batteries properly and in an environmentally sound manner. Only dispose of batteries when they are empty.

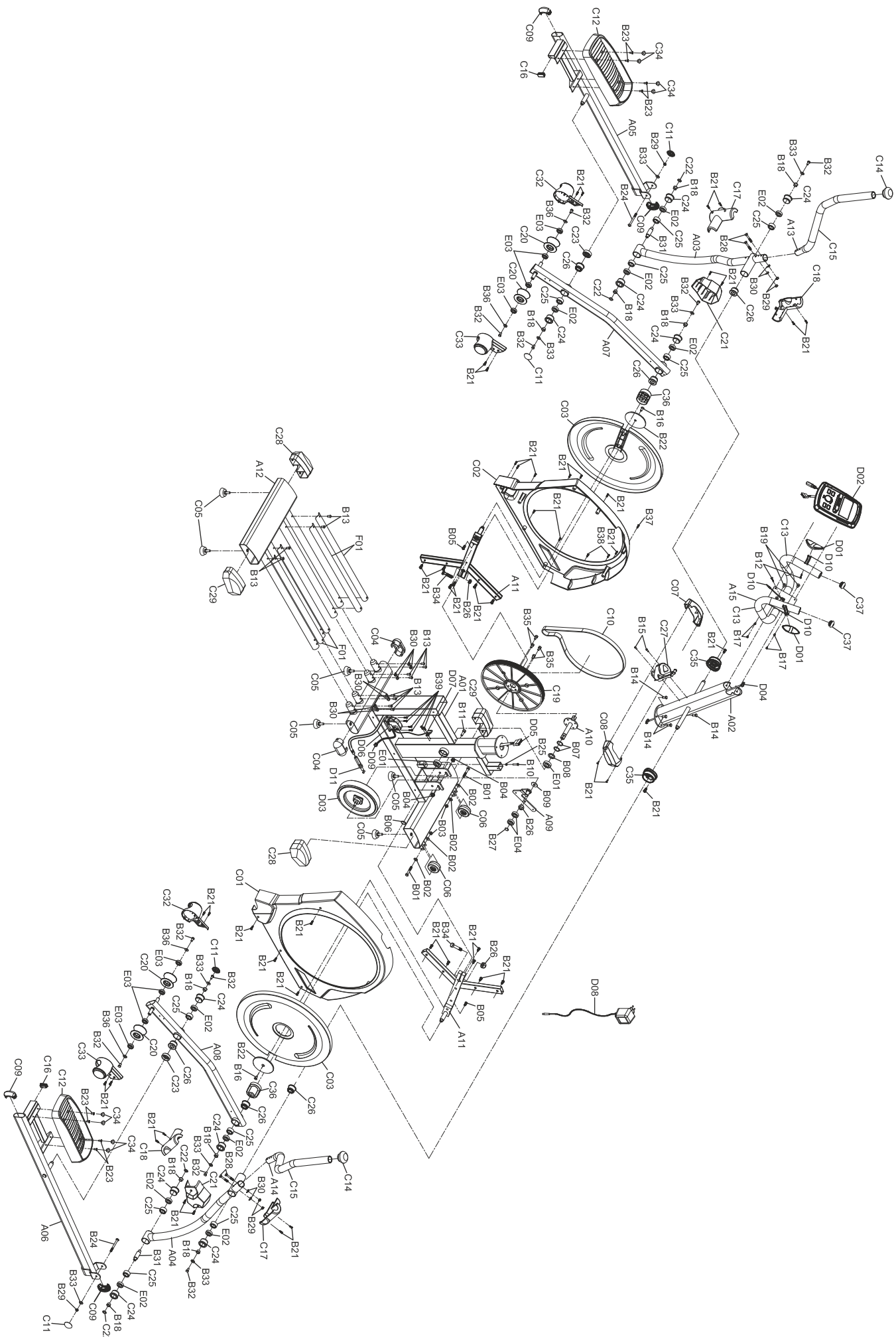

ENG

## Spare Parts List

Part No.	Description	Qty
A01	Welded,Main frame	11
A02	Welded,Upright Support	1
A03	Welded,Dual Action Left	1
A04	Welded,Dual Action Right	1
A05	Welded,Foot Pedal Tube Left	1
A06	Welded,Foot Pedal Tube Right	1
A07	Welded,Foot Tube Left	1
A08	Welded,Foot Tube Right	1
A09	Welded,Tension Wheel Arm	1
A10	Welded,Shaft Pulley	1
A11	Welded,Crank Assembly	2
A12	Welded,Guide Rails Tube	1
A13	Dual Action Handlebars Tube Left	1
A14	Dual Action Handlebars Tube	1
A15	Right Welded,Hand Bar	1
B01	1/4"Hex Bolt	2
B02	φ1/4"Washer	4
B03	1/4"Lock Nut	2
B04	3/8"Nut	2
B05	M5 Sheet Metal Screw	2
B06	C Clip	1
B07	M20 Wave Washer	2
B08	M20 Washer	1
B09	φ10 Washer	1
B10	M8 Hex Head Screw	1
B11	M10 Allen Key Screw	1
B12	M3 Sheet Metal Screw	2
B13	M8 Allen Key Screw	12
B14	M8 Hex Head Screw	4
B15	M5 Screw	2
B16	M8 Screw	2
B17	Screws For Computer	2
B18	Bushing Spacer	10
B19	M8 Screw	2
B21	M5 Sheet Metal Screw	49
B22	Zinc Plate	2
B23	M6 Allen Key Screw	8
B24	M8 Allen Key Screw	2
B25	M8 Black Nut	1
B26	M10 Lock Nut	3
B27	C Clip	1
B28	M8 Carriage Bolt	4
B29	M8 Lock Nut	6
B30	M8 Curve Washer	12
B31	Shaft for dual action arm pivot	2
B32	M8 Hex Head Screw	10
B33	φ5/16" Washer	8
B34	M10 Hex Head Screw	2
B35	M8 Allen Key Screw	4
B36	φ5/16" Washer	4
B37	3/16" Sheet Metal Screw	1
B38	M3 Sheet Metal Screw	2

Part No.	Description	Qty
B39	M4 Sheet Metal Screw	6
C01	Main Cover- Right	1
C02	Main Cover- Left	1
C03	Disc Cover	2
C04	End Cap for Stabilizer Bar	2
C05	Height Adjuster	6
C06	Transportation Wheel	2
C07	Joint Cover L	1
C08	Joint Cover R	1
C09	End Cap for Foot Pedal Tube	2
C10	Hutchinson Belt	1
C11	Nut Cap	4
C12	Foot Pedal	2
C13	Foam Grip	2
C14	Dual Action Arm Knob	2
C15	Foam Grip	2
C16	Square End Cap	2
C17	Pivot Cover L	2
C18	Pivot Cover R	2
C19	Pulley	1
C20	Roller	4
C21	Pivot Cap for Crank Link Tube	2
C22	Washer	4
C23	Spacer	2
C24	Bearing Bushing	10
C25	Bearing Housing	10
C26	Bushing	6
C27	Water Bottle Holder	1
C28	D Shape End Cap for Stabilizer Bar L	2
C29	D Shape End Cap for Stabilizer Bar R	2
C32	Wheel Cap L	2
C33	Wheel Cap R	2
C34	Foot Pedal Plug	8
C35	Upright Tube Spacer	2
C36	Small Crank Decorated Cover Hand	2
C37	End Cap	2
D01	Pulse Sensor	1
D02	Computer	1
D03	Magnetic Flywheel	1
D04	Cable	1
D05	Cable	1
D06	Motor with cable	1
D07	Sensor Cable	1
D08	AC Adapter	1
D09	AC Plug Cable	1
D10	Motor Tension cable	1
D11	Hand pulse cable	1
E01	Bearing 6004	2
E02	Bearing 6003	10
E03	Bearing 6902	8
E04	Bearing	2
F01	Aluminum Guide Rail	4

**My training device makes noises during training – is this normal?**

Your MAXXUS® training device is equipped with high-quality ball-bearings and a grooved belt. In addition, it also has a high-quality magnetic braking system which is completely wear and friction free. All these extremely high-quality components ensure that all functional noises are very much reduced. Your MAXXUS® training device is one of the quietest products available in the fitness market. However, it is possible and normal that slight mechanical noises are noticeable during training. These mechanical noises, which either continually or sometimes occur at certain intervals are created by the very high rotational speed of the flywheel. Also, moving parts may generate sounds during training, which are amplified by the hollow metal tubes of the frame. It is also quite normal for running noise to get louder during your workout. This can be explained by an increase in training speed and by the device components heating up and expanding during training.

**The cockpit does not show anything in the display when I turn it on.**

Check if the power cable is both attached correctly to the device and properly plugged into the socket, and/or if it is damaged. Check if the control cable has been pinched or jammed during assembly and / or if the connector has come loose.

**The pulse rate value is not shown or is indicated incorrectly**

Please refer to the „Pulse & Heart Rate Measurement“ sections in this manual.

**The hand pulse rate sensors are not functioning**

Check if the hand sensor cables have been pinched or jammed during assembly.

**The speed and distance values are indicated to be „0“ during training.**

Check if the control cable has been pinched or jammed during assembly and/or if the connections have come loose.

**My training device makes creaking noises during training.**

Check if the training device is standing straight and flat on the ground. If not, re-adjust the foot stands. Check if the screws at the articulated joint between the pendulum tubes and the pedal arms are tightened securely.

**My feet fall asleep during training.**

The reason for this is often that training shoes are done up too tightly. Your feet will expand when you are under exertion and so you should do up your shoes more loosely. You can also get advice regarding this from sports shops or specialist running shoe shops.

**Recommended Accessories**

ENG

These accessories are best suited for use with your training device. All products are available from our online shop at [www.maxxus.com](http://www.maxxus.com).

**POLAR® Transmitter Chest Belt T34 (uncoded)**

Chest strap for determining the heart rate with optimized transmission ranges. Required accessory for the application of pulse-controlled programs and for continuous determination of the current heart rate.

**MAXXUS® Floor Protection Mats**

Due to its extreme density and material thickness of 0,5cm, these mats provide perfect protection for floors and floor coverings against damaging, scratches and soiling through body sweat. Noise caused by running and movement is significantly reduced.

Available in the following sizes:

- 160 x 90 cm
- 210 x 100 cm

**MAXXUS® Degreaser Spray** - Optimum cleaner for cleaning off dirt and maintaining the guide pipes and roller surfaces.

**MAXXUS® Lubricating Spray** – Optimum lubrication for guide pipes.

**MAXXUS® Anti-Static Spray** – Effective against the static charges created in frames, clothing and training computers. Devices which are located on carpets or synthetic floors will become statically charged. MAXXUS® Anti-Static Spray will deter this. Synthetic surfaces treated with MAXXUS® Anti-Static Spray do not attract dust as quickly and will remain clean for longer.

**MAXXUS® Special Foam Cleaner** – Use for regular cleaning of your training device. Plastic covers and metal frames can be easily cleaned and perfectly maintained with MAXXUS® Special Foam Cleaner. It is also suitable for cleaning pulse belts and other training accessories.









For MAXXUS® Support Team to help you as quickly as possible with service, we will require certain information about your fitness device and about you. To find the exact spare parts required, we will need the product name, date of purchase and serial number.

If necessary, please fill out completely the Service Contract form attached to this User Manual and send it to us by post or you are welcome to use our online form "Service Contract" which you will find under the "Service" section at [www.maxxus.com](http://www.maxxus.com)

### Areas of Application & Warranty Periods

Depending on the model, fitness devices from MAXXUS® are suitable for use in different areas. Find the appropriate area of use for your fitness device from the "Technical Data" in this User Manual.

#### Home Use:

Exclusively for private use  
Warranty Period: 2 Years

#### Semi-Professional Use:

Use under instruction in hotels, physiotherapy practices, etc.  
Use in a fitness studio or similar establishment is hereby excluded!  
Warranty Period: 1 Year

#### Professional Use:

Use in a fitness studio or similar establishment under supervision by trained personnel.  
Warranty Period: 1 Year

Use of your training device in an area which is not suitable for your device will cause immediate expiry of its guarantee and cancel your right to claim warranty!

Sole private use and warranty period of 2 years assumes that the purchase invoice is made out to the end user.

#### Proof of Purchase and Serial Number

To claim your right to service works within the warranty period we will in each case require proof of purchase. Keep your proof of purchase or purchase invoice in a safe place and in warranty cases send us a copy together with your Service Contract. This will ensure that we can process the service work as quickly as possible. So that we can identify which model version requires to be serviced correctly, we will require; Product Name, Serial Number and Date of Purchase.

#### Terms and Conditions of Warranty:

The warranty period for your training device starts on the date of purchase and applies solely to products which were purchased directly from the MAXXUS Group GmbH & Co KG or one of the MAXXUS Group GmbH & Co KG direct and authorised distribution partners.

The warranty covers defects caused by production or material faults and only apply to devices purchased in Germany. The warranty does not apply to damages or defects caused by culpable improper use, negligent or purposeful destruction, lack or failure to carry out maintenance and/or cleaning measures, force majeure, operational causes and to normal wear and tear, damages caused by penetration of liquids, damage caused by repairs or modifications made with spare parts from a different supplier. The warranty also does not apply for damages due to faulty assembly or damages which occur because of faulty assembly. Certain component parts will wear out during use or from normal wear and tear. This includes for example:

- Ball bearings
- Bearing bushings
- Bearings
- Drive belts
- Rollers
- Switches and push-buttons
- Treadmill belts (bands)
- Treadmill decks (running deck)

Signs of wear and tear on wearing parts are not items covered under the warranty.

For assistance with warranty service or warranty repair enquiries for devices not in Germany, please contact our Service Department at MAXXUS Group GmbH & Co KGM by sending an Email to: [service@maxxus.de](mailto:service@maxxus.de) and we will be happy to help.

#### Service Outside the Warranty and Ordering Spare Parts

The MAXXUS® Service Team is happy to be of assistance to help solve any problems with faults which may arise following expiry of the warranty period, or in cases of defects arising which are not covered by the warranty.

In this case please contact us by email direct to:

[service@maxxus.de](mailto:service@maxxus.de)

Orders for Spare Parts or Worn Parts should be sent along with information on the Product Name, spare part description and number and the quantity required to:

[spareparts@maxxus.de](mailto:spareparts@maxxus.de)

Please be informed that additional fixing materials such as screws, bolts, washers etc are not included in the scope of delivery for individual spare parts. These should be ordered separately.



**Device Details**

Product Name: **CX 6.1** Product Group: **Cross-Trainer**  
 Serial Number: \_\_\_\_\_ Invoice Number: \_\_\_\_\_  
 Date of Purchase: \_\_\_\_\_ Where Purchased: \_\_\_\_\_  
 Accessories: \_\_\_\_\_ \_\_\_\_\_

**Type of Use:**

Private Use  Commercial Use

**Personal Details**

Company: \_\_\_\_\_ Contact Person: \_\_\_\_\_  
 First Name: \_\_\_\_\_ Second Name: \_\_\_\_\_  
 Street: \_\_\_\_\_ House Number: \_\_\_\_\_  
 Post Code / Town/City: \_\_\_\_\_ Country: \_\_\_\_\_  
 E-Mail: \_\_\_\_\_ Tel.No.: \_\_\_\_\_  
 Fax. No.\*: \_\_\_\_\_ Mobile No.\*: \_\_\_\_\_

\* The fields marked with an asterisk are optional. The remaining fields are mandatory fields that must be completed.

**Fault Description**

Please enter a short description of the error as precisely as possible below:  
 (For example, when, where and how does the error occur? Frequency, after which period, at what Use, etc ....)

ENG

- A copy of the proof of purchase / invoice / receipt is attached.
- I accept the General Terms and Conditions of MAXXUS® Group GmbH & Co. KG.

I hereby instruct the company MAXXUS® Group GmbH & Co. KG to repair the above defects. In Warranty cases I will not be charged for the cost. The costs for repairs which are excluded from liability for defects in quality will be charged to me and must be settled immediately. In cases of repairs carried out on site, our staff are entitled to collect payment. This agreement is confirmed with here with my signature.

\_\_\_\_\_

Date Location Signature

Please be aware that contracts can only be processed if this form has been completed in full. Be sure to attach a copy of your purchase invoice. Send the fully completed Service Contract to:

**Post\***: Maxxus Group GmbH & Co KG, Service Department, Zeppelinstr. 2, 64331 Weiterstadt  
**Fax**: +49 (0) 6151 39735 400  
**E-Mail\*\***: customerservice@maxxus.com

\* Please stamp with sufficient postage – letters which are not sent postage paid will unfortunately not be accepted.  
 \*\* Submission by E-Mail is only possible as a scanned document with original signature.

You are welcome to use our online form "Service Contract" which you will find under the "Service" section at [www.maxxus.com](http://www.maxxus.com)

# MAXXUS<sup>®</sup>



**Maxxus Group GmbH & Co. KG**  
Zeppelinstr. 2  
D-64331 Weiterstadt  
Germany  
E-Mail: [info@maxxus.com](mailto:info@maxxus.com)  
[www.maxxus.com](http://www.maxxus.com)